

# **Instruction Manual**

**Tektronix**

**TDC-10  
Tunable Down Converter**

**070-8665-00**

**Please check for change information at the rear  
of this manual.**

First Printing October 1992  
Revised November 1993

[Faint, illegible text in the left margin]

Certificate of the Manufacturer/Importer

We hereby certify that the TDC-10 Tunable Down Converter complies with the RF Interference suppression requirements of Amtsbl.-Vfg 1046/1984.

The German Postal Service was notified that the equipment is being marketed.

The German Postal Service has the right to re-test the series and to verify that it complies.

TEKTRONIX

Bescheinigung des Herstellers/Importeurs

Hiermit wird bescheinigt, daß der/die/das TDC-10 Tunable Down Converter in Übereinstimmung mit den Bestimmungen der Amtsblatt-Verfügung 1046/1984 funkentstört ist.

Der Deutschen Bundespost wurde das Inverkehrbringen dieses Gerätes angezeigt und die Berechtigung zur Überprüfung der Serie auf Einhalten der Bestimmungen eingeräumt.

TEKTRONIX

### **NOTICE to the user/operator**

The German Postal Service requires that Systems assembled by the operator/user of this instrument must also comply with Postal Regulation, Vfg. 1046/1984, Par. 2, Sect. 1.

### **HINWEIS für den Benutzer/Betreiber:**

Die vom Betreiber zusammengestellte Anlage, innerhalb derer dies Gerät eingesetzt wird, muß ebenfalls den Voraussetzungen nach Par. 2, Ziff. 1 der Vfg. 1046/1984 genügen.

### **NOTICE to the user/operator**

The German Postal Service requires that this equipment, when used in a test setup, may only be operated if the requirements of Postal Regulation, Vfg. 1046/1984, Par. 2, Sect. 1.7.1 are complied with.

### **HINWEIS für den Benutzer/Betreiber:**

Dies Gerät darf in Meßaufbauten nur betrieben werden, wenn die Voraussetzungen des Par. 2, Ziff. 1.7.1 der Vfg. 1046/1984 eingehalten werden.



# TABLE OF CONTENTS

## Section 1: Introduction and Specifications

Instrument Functions .....	1-1
Signal Conversion and Tunability.....	1-1
Frequency Counting.....	1-2
Input Signal Level.....	1-2
Remote Interface and Interconnect.....	1-2
Specifications .....	1-3

## Section 2: Setup and Operation

Unpacking the Instrument .....	2-1
Connection and Power Up .....	2-1
Controls, Displays, and Indicators .....	2-3
Display .....	2-4
Controls.....	2-6
Counter Mode .....	2-6
Channel Selection .....	2-6
Configuration Keys.....	2-7
Remote Control.....	2-8
Indicators.....	2-8
Configuration.....	2-8
Setting Display Intensity.....	2-8
Selecting an Output IF .....	2-8
Operation .....	2-9
Selecting a Channel Table.....	2-9
Fine Tuning the Conversion Frequency.....	2-9
Selecting Preamplification.....	2-10
Tuning Lockout .....	2-10

## Section 3: Programming and Remote Operation

GPIB Operation .....	3-1
Operation over the GPIB .....	3-2
System Controller .....	3-2
Software Device Driver.....	3-2
Interconnecting Cable .....	3-3
Application Software.....	3-4
Setting up for GPIB Operation.....	3-4
Connecting the Equipment.....	3-4
Configuring the TDC-10 .....	3-4
Placing the TDC-10 On line.....	3-4
Setting the GPIB Device Address.....	3-5
Configuring the Device Driver.....	3-5
Communicating With the TDC-10.....	3-5
Preparing the Software.....	3-5
RS-232 Operation .....	3-6
Operation over the RS-232 Interface.....	3-6
System Controller .....	3-7
Software Device Driver.....	3-7
Interconnecting Cable .....	3-8
Application Software.....	3-8
Setting up for RS-232 Operation .....	3-8
Connecting the Equipment.....	3-8
Configuring the TDC-10 .....	3-8

Placing the TDC-10 On line .....	3-9
Setting the Baud Rate .....	3-9
Setting Parity.....	3-9
Selecting a Data Flow Control Method .....	3-10
Setting Output Termination .....	3-10
Selecting the Echo Mode.....	3-11
Installing and Configuring the Device Driver.....	3-11
Communicating with the Downconverter .....	3-11
Preparing the Software .....	3-12
GPIB and RS-232 Command Reference .....	3-12
CTABLE Commands .....	3-13
:CTABLE:SELECT .....	3-13
:CTABLE:CATALOG .....	3-13
:CTABLE:AOFFSET.....	3-14
:CTABLE:COPY.....	3-14
:CTABLE:DELETE.....	3-14
:CTABLE:DEFINE .....	3-14
:CTABLE:EDIT .....	3-15
Example: Creating a Channel Table .....	3-16
High-Level Queries.....	3-16
CHANNEL Commands.....	3-16
:CHANNEL:SKIP .....	3-16
:CHANNEL:SELECT.....	3-17
High-Level Queries.....	3-17
FINETUNE Command.....	3-18
TLOCK Command .....	3-18
FETCH:FREQUENCY? Query .....	3-18
:FETCH:FREQUENCY:AURAL .....	3-18
:FETCH:FREQUENCY:VISUAL.....	3-19
High-Level Queries.....	3-19
MEASURE:FREQUENCY? Query .....	3-19
:MEASURE:FREQUENCY:AURAL .....	3-19
:MEASURE:FREQUENCY:VISUAL.....	3-19
High-Level Queries.....	3-20
DEMODO Commands .....	3-20
:DEMODO:CONTROL .....	3-20
:DEMODO:DETECTOR.....	3-20
High-Level Queries.....	3-21
INTENSITY Command .....	3-21
REFERENCE? Query.....	3-21
IFREQUENCY Command.....	3-21
COUNT:DELTA Command.....	3-22
INPUT Commands .....	3-22
:INPUT:GAIN command.....	3-22
IEEE 488.2 and Tektronix Codes and Formats Commands .....	3-23
*CLS Command .....	3-23
*ESR? Query .....	3-23
*STB? Query .....	3-23
*PSC Commands .....	3-23
*ESE Commands .....	3-23
DESE Commands .....	3-24
*SRE Commands .....	3-24
*TST Command .....	3-24
*OPC Command.....	3-24
*WAI Command.....	3-25

ALLEV? Query .....	3-25
EVENT? Query .....	3-25
EVMSG? Query .....	3-25
EVQTY? Query .....	3-25
IDN? Query .....	3-25
*OPT? Query .....	3-26
FACTORY Command .....	3-26
*LRN? Query .....	3-26
*RST Command .....	3-27
HEADER Command .....	3-27
VERBOSE Command .....	3-27
LOCK Commands .....	3-27
UNLOCK Commands .....	3-28
Status and Event Handling .....	3-28
Registers .....	3-28
Status Registers .....	3-28
Enable Registers .....	3-29
The Enable Registers and the *PSC Command .....	3-30
Queues .....	3-30
Output Queue .....	3-30
Event Queue .....	3-31
Messages .....	3-31

#### Section 4: Verification and Adjustment

Introduction .....	4-1
Verification Procedures .....	4-1
Equipment Required .....	4-1
Abbreviated Testing .....	4-3
Power Up Checks .....	4-3
Internal Reference Accuracy .....	4-4
Specification .....	4-4
Cabling .....	4-4
Settings .....	4-4
Measurement Procedure .....	4-4
Video Counter Check .....	4-4
Specification .....	4-5
Cabling .....	4-5
Settings .....	4-5
Measurement .....	4-5
Audio Counter Check .....	4-5
Specification .....	4-5
Cabling .....	4-5
Settings .....	4-6
Measurement .....	4-6
External Reference Input .....	4-7
Specification .....	4-7
Cabling .....	4-7
Settings .....	4-8
Measurement .....	4-9
Input Return Loss .....	4-10
Specification .....	4-10
Cabling .....	4-10
Settings .....	4-10
Procedure .....	4-10
RF Gain and Flatness .....	4-10
Specification .....	4-10

Cabling .....	4-11
Settings .....	4-11
Procedure.....	4-12
PIN Attenuator AGC Range Check .....	4-12
Specification .....	4-12
Cabling .....	4-12
Settings .....	4-12
Procedure.....	4-13
Residual Signals .....	4-13
Specification .....	4-13
Cabling .....	4-14
Settings .....	4-14
Procedure.....	4-14
Third-Order Intercept .....	4-14
Specification .....	4-14
Cabling .....	4-15
Settings .....	4-15
Procedure.....	4-16
Second-Order Intercept .....	4-17
Specification .....	4-17
Cabling .....	4-17
Settings .....	4-17
Procedure.....	4-17
Signal-to-Noise Ratio.....	4-18
Specification .....	4-18
Cabling .....	4-18
Settings .....	4-19
Procedure.....	4-20
Noise Figure .....	4-20
Specification .....	4-20
Cabling .....	4-20
Settings .....	4-21
Procedure.....	4-21
Phase Jitter .....	4-21
Specification .....	4-22
Cabling .....	4-22
Settings .....	4-23
Procedure.....	4-24
In-Channel Magnitude Flatness.....	4-24
Specification .....	4-24
Cabling .....	4-24
Settings .....	4-24
Procedure.....	4-26
In-Channel Group Delay Flatness.....	4-26
Specification .....	4-26
Cabling .....	4-26
Settings .....	4-26
Procedure.....	4-27
GPIB Port.....	4-28
Procedure.....	4-28
RS-232 Port .....	4-28
Adjustment Procedures .....	4-29
Equipment Required.....	4-29
10 MHz Reference Oscillator.....	4-29
Cabling .....	4-29



Settings ..... 4-30  
 Procedure ..... 4-30  
 100 MHz Distribution Board ..... 4-30  
     Setup ..... 4-30  
     Procedure ..... 4-31  
 Inter-Carrier Processor Board ..... 4-31  
     Setup ..... 4-31  
     Procedure ..... 4-32  
 YIG Driver Board ..... 4-33  
     Setup ..... 4-33  
     Procedure ..... 4-33

**Section 5: Troubleshooting and Maintenance**

Introduction ..... 5-1  
 Static-Sensitive Components ..... 5-1  
 Corrective Maintenance ..... 5-2  
     Lithium Battery ..... 5-2  
         Battery Disposal ..... 5-2  
         Battery Emergency and First Aid Information ..... 5-3  
 Removal and Replacement ..... 5-3  
     Removing and replacing instrument cover panels ..... 5-3  
     Locating, Removing, and Replacing Boards and Modules ..... 5-4  
 Customer Services ..... 5-5  
     Service Support ..... 5-5  
     Exchanging TDC-10 Boards and Modules ..... 5-6  
     Customer Service Outside the U.S. .... 5-6  
 Diagnostics ..... 5-7  
     Power-Up Diagnostics ..... 5-7  
         RAM Test ..... 5-8  
         EPROM Checksum Test ..... 5-8  
         Interrupt Controller Test ..... 5-8  
         Timer Tests ..... 5-8  
         Operating System Start-Up ..... 5-8  
     User Selectable Diagnostics ..... 5-8  
         Entering Calibration Assistance Mode ..... 5-8  
         Controlling Firmware Routines ..... 5-8  
         Routine Descriptions ..... 5-9  
             YIG Driver Adjust ..... 5-9  
             Front-Panel Buttons ..... 5-9  
             Front-Panel LEDs ..... 5-9  
             Display Test ..... 5-9  
             System Clock Counter ..... 5-9  
             YIG Counter ..... 5-9  
             Visual IF Counter ..... 5-9  
             Sound IF Counter ..... 5-10  
             External Ref Counter ..... 5-10  
             Internal Ref Counter ..... 5-10  
             Set 1st LO Frequency ..... 5-10  
             RF Deck Control ..... 5-10  
             ICP Board Control ..... 5-10  
             100 MHz Ref Control ..... 5-11  
             YIG DAC Control ..... 5-11  
             Serial Bus ..... 5-11  
             Demod Control ..... 5-12  
             Scan Serial, Scan Shunt DAC ..... 5-12  
             Set PIN Attenuation ..... 5-12

Default Flash EPROM.....	5-13
Data Path Test Mode.....	5-13
Display System Stats.....	5-15
Exiting Calibration Assistance Mode.....	5-16
Introduction to Troubleshooting.....	5-16
Troubleshooting Aids.....	5-16
Foldout Pages.....	5-16
Parts Lists.....	5-17
Major Assembly Interconnection.....	5-17
General Troubleshooting Techniques.....	5-17
Troubleshooting the Instrument.....	5-18
Preamplifier Troubleshooting.....	5-19
RF Deck Troubleshooting.....	5-19
LO Amplifier Troubleshooting.....	5-19
YIG Divider Troubleshooting.....	5-20
Frequency Control Section Troubleshooting.....	5-20
Phase Lock Interface.....	5-20
100 Mhz Phase Reference.....	5-20
10 Mhz Reference Oscillator.....	5-20
1st Local Oscillator.....	5-21
DAC/YIG Driver.....	5-21
Phase Gate Detector Assembly.....	5-21
Phase Lock Assembly.....	5-21
External Lock Problems.....	5-21

**Section 6: Theory of Operation**

Introduction.....	6-1
Preamplifier (A18).....	6-2
1st Converter (A12A19).....	6-2
2nd Converter (A12A20).....	6-2
2 GHz Second Local Oscillator.....	6-2
2 GHz Voltage Controlled Oscillator (VCO).....	6-3
LO Amplifier.....	6-3
Control Loop.....	6-3
Second Mixer.....	6-3
Voltage Regulators.....	6-3
2nd IF Bandpass Filter (A12A21).....	6-4
3rd Converter (A12A22).....	6-4
Local Oscillator Port and Frequency Multiplier.....	6-5
RF Port.....	6-5
IF Port.....	6-5
RF Deck Interface (A12A23).....	6-5
Microprocessor (A11).....	6-6
CPU.....	6-6
Memory and Peripherals.....	6-7
RS-232C and GPIB.....	6-7
Status Ports.....	6-8
Front-Panel Interface.....	6-8
Frequency Control.....	6-9
General Frequency Counter.....	6-9
Amplitude Control.....	6-9
PIN Attenuator Driver.....	6-10
Analog I/O.....	6-10
Inter-Carrier Processor Board (A15).....	6-11
Signal and Power Interface.....	6-11
Control System Interface.....	6-12

Circuit Description.....	6-13
10 MHz Reference Oscillator (A14).....	6-14
LO Amplifier (A17).....	6-14
1st Lo Assembly (YIG Oscillator, A1).....	6-14
100 MHz Phase Reference (A16).....	6-14
Phase Lock Interface (A2).....	6-15
DAC/YIG Driver (A3).....	6-16
Counter and Phase Lock Section (A5).....	6-17
Phase Lock assembly Block Description.....	6-17
Circuit Description.....	6-19
Phase Lock Synthesizer.....	6-19
Error Amplifier.....	6-20
Controlled Oscillator (VCO).....	6-21
Offset Mixer.....	6-22
Strobe Driver Circuit.....	6-23
YIG Divider (A9).....	6-23
Phase Gate Detector Assembly (A4).....	6-23
Serial Filter (A10).....	6-24
Front Panel (A8A1).....	6-24
Front Panel Display (A8A2).....	6-24
Power Supply Assembly (A6).....	6-24

## Appendix

Introduction.....	A-1
Microprocessor Board DIP Switch Settings.....	A-1
Connector Descriptions.....	A-2
Error Messages.....	A-5
Channel Tables.....	A-11

## LIST OF FIGURES

2-1.	Front- and rear-panel cable connections (shown for 75 $\Omega$ systems).....	2-2
2-2.	Front-panel layout.....	2-4
2-3.	Downconverter display in normal operation.....	2-5
2-4.	Channel selection keypad.....	2-6
2-5.	Configuration keypad.....	2-7
3-1.	Typical Small Instrument System for GPIB.....	3-3
3-2.	The GPIB Status menu.....	3-4
3-3.	The GPIB Address menu.....	3-5
3-4.	RS-232 System Configurations.....	3-7
3-5.	First RS-232 port configuration menu.....	3-9
3-6.	RS-232 baud rate display.....	3-9
3-7.	RS-232 Parity display.....	3-10
3-8.	RS-232 Flow Control display.....	3-10
3-9.	RS-232 Output Termination display.....	3-10
3-10.	RS-232 Echo Mode display.....	3-11
4-1.	Internal reference accuracy test setup.....	4-4
4-2.	Audio counter check test setup.....	4-6
4-3.	External reference input test setup.....	4-8
4-4.	RF gain and flatness test setup.....	4-11
4-5.	Residual signals procedure setup.....	4-14
4-6.	Third-order intercept procedure setup.....	4-15
4-7.	Signal-to-noise ratio procedure setup.....	4-19
4-8.	Phase jitter setup.....	4-22
4-9.	Internal reference accuracy test setup.....	4-29

4-10.	Inter-Carrier Processor board adjustment setup.....	4-31
5-1.	TDC-10 circuit board locations. ....	5-4
6-1.	Phase lock assembly block.....	6-18
A-1.	S1 DIP switch positions for normal operation.....	A-1
A-2.	GPIB port pin definitions. ....	A-3
A-3.	RS-232 port pin definitions. ....	A-4

**LIST OF TABLES**

1-1	Electrical Characteristics.....	1-3
1-2	System Characteristics.....	1-7
1-3	Communication Ports and Interfaces.....	1-8
1-4	Power Requirements.....	1-9
1-5	Weights and dimensions.....	1-9
1-6	Environmental Characteristics.....	1-10
1-7	Miscellaneous Characteristics.....	1-11
3-1	Argument types and allowable ranges.....	3-14
3-2	SESR bit functions.....	3-30
3-3	SBR bit functions.....	3-31
3-4	No event messages.....	3-33
3-5	Command error messages – CME Bit 5.....	3-33
3-6	Execution error messages – EXE Bit 4.....	3-33
3-7	Device error messages – DDE Bit 3.....	3-33
3-8	System event messages – QYE Bit 2.....	3-34
3-9	Execution warning message – EXE Bit 4.....	3-34
3-10	Internal warning messages – DDE Bit 3.....	3-34
3-11	Extended execution error messages – EXE Bit 4.....	3-34
3-12	Extended device-specific error messages – DDE Bit 3.....	3-35
4-1.	Equipment required for performance verification.....	4-1
4-2.	Recommended test channels for abbreviated instrument verification.....	4-3
4-3.	Channel table audio offsets.....	4-6
4-4.	Preamp settings and required power sensor heads.....	4-11
4-5.	Recommended second-order intercept settings.....	4-18
4-6.	Equipment required for adjustment procedures.....	4-29
5-1	Static Susceptibility.....	5-1
5-2	Emergency Procedures for Contact with Lithium Battery Contents.....	5-3
5-3	Exchangeable TDC-10 circuit assemblies. ....	5-6
5-4	Power-Up Diagnostics Indicators. ....	5-7
5-5	Firmware Routine Function Controls.....	5-9
5-6	Port and Indicator Names.....	5-12
5-7	Basic troubleshooting symptoms and corrective actions.....	5-18
A-1	AGC DATA IN signal names and functions (9-pin D-shell connector).....	A-2
A-2	REMOTE IN, REMOTE OUT connector pin functions.....	A-3

# OPERATOR SAFETY SUMMARY

*The general safety information in this part of the summary is for both operating and servicing personnel. Specific warnings and cautions will be found throughout the manual where they apply, but may not appear in this summary.*

## TERMS

### In This Manual

**CAUTION** statements identify conditions or practices that could result in damage to the equipment or other property.

**WARNING** statements identify conditions or practices that could result in personal injury or loss of life.

### As Marked on Equipment



**CAUTION** indicates a personal injury hazard not immediately accessible as one reads the marking, or a hazard to property, including the equipment itself. Refer to the manual for information.



**DANGER** indicates a personal injury hazard immediately accessible as one reads the marking.



Protective ground (earth) terminal.

## SAFETY INFORMATION

**Use the Proper Power Source.** This product is intended to operate from a power source that will not apply more than 250 V rms between the supply conductors or between either supply conductor and ground. A protective-ground connection by way of the grounding conductor in the power cord is essential for safe operation.

**Ground the Product.** This product is grounded through the grounding conductor of the power module power cord. To avoid electrical shock, plug the power cord into a properly wired receptacle before connecting to the product input or output terminals. A protective-ground connection by way of the grounding conductor in the power module power cord is essential for safe operation.

**Danger May Arise From Loss of Ground.** Upon loss of the protective-ground connection, all accessible conductive parts (including knobs and controls that may appear to be insulating) can render an electric shock.

**Use the Proper Fuse.** To avoid fire hazard, use only the fuse of correct type, voltage rating, and current rating as specified in the parts list for your product. Refer fuse replacement to qualified service personnel.

**Do Not Operate in Explosive Atmospheres.** To avoid explosion, do not operate this product in an explosive atmosphere.

**Do Not Remove Covers.** To avoid personal injury, do not remove the product covers or panels. Do not operate the product without the covers and panels properly installed.

## SERVICING SAFETY SUMMARY

*For Qualified Service Personnel only. Refer also to the preceding Operators Safety Summary.*

**Do Not Service Alone.** Do not perform internal service or adjustment of this product unless another person capable of rendering first aid and resuscitation is present.

**Use Care When Servicing With Power On.** Dangerous voltages exist at several points in this product. To avoid personal injury, do not touch exposed connections or components while power is on. Disconnect power before removing protective panels, soldering, or replacing components.

**Use the Proper Power Source.** This product is intended to operate from a power source that will not apply more than 250 V rms between the supply conductors or between either supply conductor and ground. A protective-ground connection by way of the grounding conductor in the power cord is essential for safe operation.



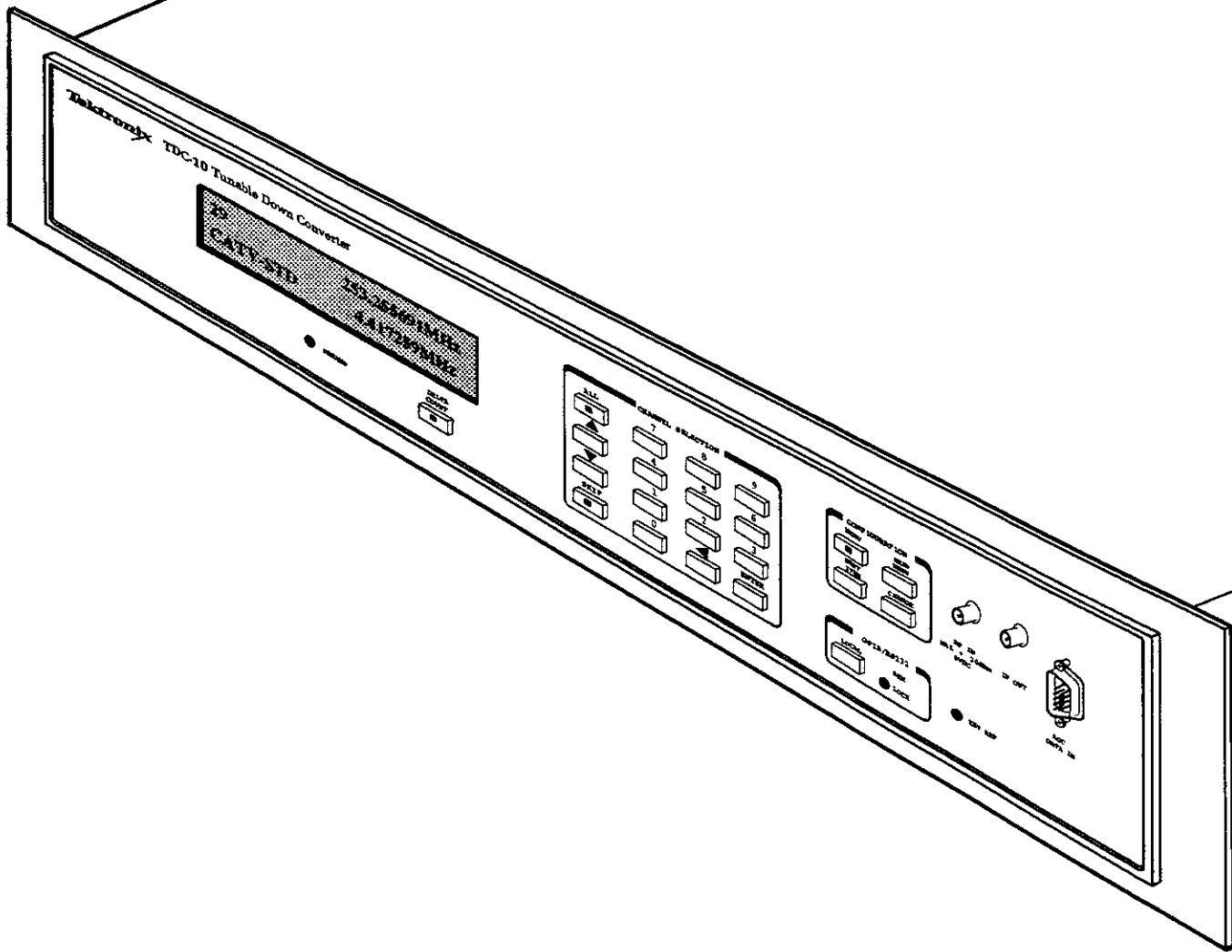

**The TDC-10 Tunable Down Converter**



# Section 1

## INTRODUCTION AND SPECIFICATIONS

A high-performance front end for the Tektronix 1450-series Television Demodulator, the TDC-10 Tunable Down Converter selects incoming television carriers and converts them to an intermediate frequency compatible with the 1450. Features of the 1450/TDC-10 Television Demodulator System include:

- Electronically tunable input capable of selecting television channels between 40 MHz and 1.076 GHz and converting them to a 37.0 MHz, 38.0 MHz, 38.9 MHz, or 45.75 MHz intermediate frequency
- User programmable custom channel assignments
- Fluorescent display that shows input signal video carrier frequency, audio carrier offset, channel table, and channel number
- GPIB or RS-232C controllable interfaces

A wide AGC range accepts strong signals from transmitter test points and CATV systems, or weak signals from antennas for remote monitoring; all without affecting the bandpass characteristics of the 1450/TDC-10 system. The TDC-10 enhances selectivity around the channel frequency by limiting IF feedthrough and image frequencies.

### INSTRUMENT FUNCTIONS

The TDC-10 provides three basic functions:

- Converts an incoming video/audio-modulated RF signal into a modulated IF signal that can be used by a separate demodulator and video test set to measure the video signal
- Counts video carrier and audio carrier offset frequencies
- Allows remote control of all front-panel functions and some 1450 Television Demodulator remote functions

The following sections discuss these features in detail.

#### Signal Conversion and Tunability

The TDC-10 lets you control the conversion frequency and target IF frequency via menu selections.

You may tune any channel in the TDC-10's frequency range by selecting the channel number. Three methods of tuning are possible:

- Direct Entry — Enter any channel by number
- Up/Down — Select channels sequentially
- Up/Down with skipped channels — Skip or delete a channel from the up/down sequence (lets you skip unused or unwanted channels when selecting channels to test)

You may control which channels the TDC-10 tunes during an up/down sequence by selecting the appropriate channel table and using the skip function.

You may also select one of several built-in channel tables. The current channel table selection includes: B'Cast (broadcast VHF/UHF), CATV-STD, CATV-HRC, CATV-IRC, Eur-BG, Eur-I, China-DK, and Japan-M.

You may define your own channel tables through the remote interface. This enables you to use the TDC-10 with uncommon or unusual channel spacings and allows you to customize the channel order.

Besides channel tuning, you may also fine tune the TDC-10 in approximately 50 kHz steps. This lets you control the conversion frequency in the special situation where the input frequency isn't close to one of the channel-table channels.

Front-panel tuning may be locked out by invoking Tuning Lockout mode. This limits accidental or unauthorized channel tuning at the instrument front panel.

## Frequency Counting

When the TDC-10 detects a signal, it counts the visual carrier and aural carrier offset frequencies. Frequencies are displayed on the front panel and, when requested, can be sent through the remote interface. Frequencies are displayed repetitively as the system acquires new frequency samples.

Frequency count results can be displayed as actual signal frequency or as frequency difference from the frequency stored in the channel table.

## Input Signal Level

Input signal levels are user controllable. When a low-level signal is to be converted, one or two stages of preamplification can be switched in. Since this changes the conversion loss through the TDC-10, the 1450 amplitude readout does not represent the input signal level when preamplifiers are used.

## Remote Interface and Interconnect

The TDC-10 contains two remote interfaces for controlling the instrument as an extension of the front panel.

1. The GPIB (IEEE 488.2-1987) interface is a bit-parallel byte-serial two-way communications port. This port is used for instrument control and measurement read back.
2. The RS-232 interface is a serial two-way communications port, used like GPIB for control and read back.

Three interface connectors allow communication with the 1450.

- The AGC Data In connector (on the TDC-10 front panel) allows the AGC system in the 1450 to set the attenuation in the TDC-10
- The Remote Out connector (on the TDC-10 rear panel) allows the carrier loss alarm signal to be passed through to the remote interface, and allows the remote interface to select envelope or synchronous detection modes in the 1450
- The Remote In connector (also on the TDC-10 rear panel) allows the carrier loss alarm signals to exit the TDC-10

# SPECIFICATIONS

Table 1-1. Electrical Characteristics

Characteristic	Performance Requirement	Supplemental Information		
Frequency Related Characteristics				
RF Input Frequency ( $F_{in}$ )	$F_{in}$ must be within $\pm 120$ kHz of nominal channel frequency	40 MHz to 1.076 GHz, AC coupled, SMA female compatible with Tektronix 1450 mainframe. Instrument can be fine tuned in approximately 50 kHz steps.		
Frequency Counter		Measures center frequency of video carrier and frequency offset of audio carrier. Also measures frequency offset of audio carrier and video carrier.		
Range		40 MHz to 1.076 GHz		
Resolution		1 Hz		
Accuracy (Internal Reference)	$(\text{Int. Ref. Accuracy}) \times (F_{in}) \pm 2$ Hz			
Accuracy (External Reference)	$(\text{Ext. Ref. Accuracy}) \times (F_{in}) \pm 2$ Hz			
Sensitivity measured at TDC-10 IF output	-50 dBm (Min)	The smallest signal that can be counted; requires signal-to-noise ratio of at least 30 dB		
Frequency Reference Accuracy		$\leq 1 \times 10^{-9}$ per day <sup>1</sup> $1 \times 10^{-8}$ per week <sup>1</sup> $\leq 1 \times 10^{-7}$ during first 6 months <sup>1</sup> $2 \times 10^{-7}$ per year <sup>1</sup>		
Aging rate of 10 MHz reference				
Temperature Drift		$< 2 \times 10^{-8}$ over 0 to 50° C referenced to +25° C		
Setability		$\leq \pm 1 \times 10^{-8}$ of 10 MHz <sup>1</sup> After 1 week stabilization		
Amplitude-Related Characteristics				
Return Loss (50 $\Omega$ system)		RF Atten	Center Freq	Return Loss
		0 dB	40 MHz-550 MHz	$\geq 8.5$ dB
		0 dB	550 MHz-1.076 GHz	$\geq 6$ dB
		$\geq 10$ dB	40 MHz-1.076 GHz	$\geq 20$ dB
Maximum input amplitude without damage		+20 dBm continuous AC with 0 dB attenuation: 0 Volts DC.		

Table 1-1. Electrical Characteristics (cont.)

Characteristic	Performance Requirement	Supplemental Information
Amplitude flatness (in video bandwidth) 50 MHz – 1.076 GHz	$\leq \pm 0.4$ dB ( $\pm 4.7\%$ )	VBW = 4.2 MHz
	$\leq \pm 0.65$ dB ( $\pm 7.8\%$ )	VBW = 5.0 MHz, 5.5MHz, 6.0MHz
Group delay variation		$\leq \pm 6$ nsec across video bandwidth
Gain		
40 – 550 MHz	Gain = 1 dB +0, –4 dB	Preamp Gain = –0 dB
	Gain = 18dB +0, –4 dB	Preamp Gain = –17 dB
550 – 860 MHz	Gain = 28 dB +0, –4 dB	Preamp Gain = –27 dB
	Gain = 0 dB +0, –5 dB	Preamp Gain = –0 dB
	Gain = 17 dB +0, –5 dB	Preamp Gain = –17 dB
860 – 1,076 MHz	Gain = 27 dB +0, –5 dB	Preamp Gain = –27 dB
	Gain = 0 dB +0, –8 dB	Preamp Gain = –0 dB
	Gain = 17 dB +0, –8 dB	Preamp Gain = –17 dB
	Gain = 27 dB +0, –8 dB	Preamp Gain = –27 dB
		PIN attenuator set to min attenuation. IF at 45.75 MHz.
AGC Range		0 to $22.23 - \frac{f(\text{MHz})}{236.25}$ dB
Residual signals (preamp on)	< –101 dBm $\leq -85$ dBm for $F_{in} = 85 - 110$ MHz	Signals independent of input signal in TDC-10 passband (31.5 MHz to 47 MHz).
IF and image rejection ratio		> 65 dB
Third-order intercept point (two-tone, 2 MHz spacing)	>10 dBm	Preamp Gain = –0 dB
	> –7 dBm	Preamp Gain = –17 dB
	> –17 dBm	Preamp Gain = –27 dB
Third-order intercept > 15 MHz spacing		16 dBm
Composite triple beat (CTB) (78 channels, 6 MHz spacing, CW carriers)		> 58 dBc: Preamp Gain = –0 dB RF input level: –21 dBm <sup>1</sup>
		> 58 dBc: Preamp Gain = –17 dB RF input level: –38 dBm <sup>1</sup>
		> 58 dBc: Preamp Gain = –27 dB RF input level: –48 dBm <sup>1</sup>
		<sup>1</sup> each tone
Second-order intercept point (two-tone)	> 45 dBm	Preamp Gain = –0 dB
	> 28 dBm	Preamp Gain = –17 dB
	> 18 dBm	Preamp Gain = –27 dB

Table 1-1. Electrical Characteristics (cont.)

Characteristic	Performance Requirement	Supplemental Information																				
Composite second-order (CSO) (78 channels, 6 MHz spacing, CW carriers)		> 60 dBc: Preamp Gain = -0 dB RF input level: -21 dBm  > 60 dBc: Preamp Gain = -17 dB RF input level: -38 dBm  > 60 dBc: Preamp Gain = -27 dB RF input level: -48 dBm																				
<b>IF Output Signal Characteristics</b>																						
IF Output Connector		50 Ω BNC (female), compatible with Tektronix 1450 mainframe																				
Return Loss		≥ 20 dB																				
Amplitude	-64 dBm (with -65 dBm input) to -20 dBm (input ≥ -21 dBm) ±1.5 dB	IF out is nominally equal to RF Input for levels between -67 dBm and -23 dBm, and -20 for RF Input levels between -23 and +1 dBm when connected to 1450 demodulator.																				
		<table border="1"> <thead> <tr> <th>RF Input</th> <th>Nominal IF Output</th> </tr> </thead> <tbody> <tr> <td colspan="2" style="text-align: center;"><b>(Preamp Gain = -0 dB)</b></td> </tr> <tr> <td>-65 to -23 dBm</td> <td>-64 to -20 dBm</td> </tr> <tr> <td>-23 to -1 dBm</td> <td>-20 dBm</td> </tr> <tr> <td colspan="2" style="text-align: center;"><b>(Preamp Gain = -17 dB)</b></td> </tr> <tr> <td>-82 to -40 dBm</td> <td>-64 to -20 dBm</td> </tr> <tr> <td>-40 to -18 dBm</td> <td>-20 dBm</td> </tr> <tr> <td colspan="2" style="text-align: center;"><b>(Preamp Gain = -27 dB)</b></td> </tr> <tr> <td>-92 to -50 dBm</td> <td>-64 to -20 dBm</td> </tr> <tr> <td>-50 to -28 dBm</td> <td>-20 dBm</td> </tr> </tbody> </table>	RF Input	Nominal IF Output	<b>(Preamp Gain = -0 dB)</b>		-65 to -23 dBm	-64 to -20 dBm	-23 to -1 dBm	-20 dBm	<b>(Preamp Gain = -17 dB)</b>		-82 to -40 dBm	-64 to -20 dBm	-40 to -18 dBm	-20 dBm	<b>(Preamp Gain = -27 dB)</b>		-92 to -50 dBm	-64 to -20 dBm	-50 to -28 dBm	-20 dBm
RF Input	Nominal IF Output																					
<b>(Preamp Gain = -0 dB)</b>																						
-65 to -23 dBm	-64 to -20 dBm																					
-23 to -1 dBm	-20 dBm																					
<b>(Preamp Gain = -17 dB)</b>																						
-82 to -40 dBm	-64 to -20 dBm																					
-40 to -18 dBm	-20 dBm																					
<b>(Preamp Gain = -27 dB)</b>																						
-92 to -50 dBm	-64 to -20 dBm																					
-50 to -28 dBm	-20 dBm																					

Table 1-1. Electrical Characteristics (cont.)

Characteristic	Performance Requirement		Supplemental Information
Available IF frequencies	Video	Audio Offset	Video IF is menu-selectable. Audio offsets are determined by channel table.
	45.75 $\pm$ 120 kHz	4.5 MHz	
	38.90 $\pm$ 120 kHz	4.5 MHz	
	38.90 $\pm$ 120 kHz	5.5 MHz	
	38.90 $\pm$ 120 kHz	5.74 MHz	
	38.90 $\pm$ 120 kHz	6.0 MHz	
	38.90 $\pm$ 120 kHz	6.5 MHz	
	38.0 $\pm$ 120 kHz	5.5 MHz	
	38.0 $\pm$ 120 kHz	6.5 MHz	
37.0 $\pm$ 120 kHz	4.5 MHz		
Rear-Panel Signal Characteristics			
GPIB and RS-232 connectors			Both interfaces on standard unit. See Table 1-3 for complete specifications. Only one interface in use at a time.
75 $\Omega$ input to 50 $\Omega$ output loop through RF Input Range			40 MHz to 1.076 GHz with 75 $\Omega$ , Type F connector
RF Output Range			40 MHz to 1.076 GHz with 50 $\Omega$ , Type N connector
Input VSWR, 75 $\Omega$			< 2.0:1
Output VSWR, 50 $\Omega$			< 2.0:1
Insertion Loss			< 1 dB
Maximum Input Level for specified operation			+ 50 dBmV
External Reference Input Frequency			1, 2, 5, or 10 MHz; auto-selected
Signal Level	0 to +10 dBm		20 VDC maximum
Input Impedance			50 $\Omega$ BNC Female, 50 $\Omega$ nominal
Internal Reference Output Frequency			10 MHz, see Frequency reference accuracy for complete specification.
Signal Level	+5 to +10 dBm		+7 dBm nominal

Table 1-2. System Characteristics: TDC-10 and 1450

Characteristic	Performance Requirement	Supplemental Information										
RF Attenuation		Range: 30 dB; resolution: 10 dB. Input level range shifts with attenuator setting as shown below: <table border="1" style="margin-left: auto; margin-right: auto;"> <thead> <tr> <th>RF Attenuation</th> <th>(Preamp Gain = 0) Input Level Range</th> </tr> </thead> <tbody> <tr> <td>0 dB</td> <td>+1 dBm to -65 dBm</td> </tr> <tr> <td>10 dB</td> <td>+11 dBm to -55 dBm</td> </tr> <tr> <td>20 dB</td> <td>+21 dBm to -45 dBm</td> </tr> <tr> <td>30 dB</td> <td>+31 dBm to -35 dBm</td> </tr> </tbody> </table>	RF Attenuation	(Preamp Gain = 0) Input Level Range	0 dB	+1 dBm to -65 dBm	10 dB	+11 dBm to -55 dBm	20 dB	+21 dBm to -45 dBm	30 dB	+31 dBm to -35 dBm
RF Attenuation	(Preamp Gain = 0) Input Level Range											
0 dB	+1 dBm to -65 dBm											
10 dB	+11 dBm to -55 dBm											
20 dB	+21 dBm to -45 dBm											
30 dB	+31 dBm to -35 dBm											
Noise Figure (40 MHz – 550 MHz) For preamp gain = -0 dB For preamp gain = -17 dB For preamp gain = -27 dB	$\leq 25$ dB $\leq 13$ dB $\leq 9$ dB	With 0 dB RF attenuation With 0 dB RF attenuation With 0 dB RF attenuation										
Noise Figure (550 MHz – 860 MHz) For preamp gain = -0 dB For preamp gain = -17 dB For preamp gain = -27 dB	$\leq 26$ dB $\leq 14$ dB $\leq 10$ dB	With 0 dB RF attenuation With 0 dB RF attenuation With 0 dB RF attenuation										
Noise Figure (860 MHz – 1076 MHz) For preamp gain = -0 dB For preamp gain = -17 dB For preamp gain = -27 dB	$\leq 30$ dB $\leq 18$ dB $\leq 14$ dB	With 0 dB RF attenuation With 0 dB RF attenuation With 0 dB RF attenuation										
Ultimate signal-to-noise ratio (weighted)	$> 60$ dB	For input levels greater than -21 dBm (4.5 MHz BW)										
AGC range	61 dB	$0$ to $22.23 - \frac{f(\text{MHz})}{236.25}$ for TDC-10 and approx. 44 dB for 1450.										
Phase jitter	1.50° peak	Using Tektronix 1480 measurement method										
Adjacent channel cross-modulation		$\geq 60$ dBc: adjacent channel signal $\leq$ the desired channel signal										
2nd adjacent channel cross-modulation		$\geq 60$ dBc: 2nd adjacent channel signal $\leq$ the desired channel signal										
Variation in system frequency response across the channel	$\leq \pm 0.5$ dB $\leq \pm 0.75$ dB	With 1450 sound trap out. VBW = 4.2 MHz VBW = 5.0 MHz, 5.5 MHz, 6.0 MHz										

Table 1-2. System Characteristics: TDC-10 and 1450 (cont.)

Characteristic	Performance Requirement	Supplemental Information
Amplitude flatness	$\leq 0.25$ dB p-p amplitude	Variation across RF bandwidth as a function of AGC Preamp gain = $\sim 0$ dB $RF_{in} = -15$ dBm
Gain variation	$\leq 2$ dB	Between different IF filters
Chrominance/audio carrier/video carrier intermodulation		$> 50$ dBc: 3-tone test

Table 1-3. Communication Ports and Interfaces

Characteristic	Performance Requirement	Supplemental Information
Remote interface ports		GPIB: IEEE Std. 488.1 (1987), 488.2 (1987). RS-232: EIA RS-232C. Ports comply with Tektronix Codes and Formats, 1991, where applicable.
GPIB interface functions		SH1, AH1, SR1, PP0, DT0, C0, and E2 T6: full support except talk only RL1: full support including local lockout DC1: full support including selected device clear
RS-232 interface functions		The TDC-10 implements the DTE (terminal) side of the RS-232C interface.
Baud rates		110, 150, 300, 600, 1200, 2400, 4800, and 9600
Bits per character		7 (ASCII transfers only)
Parity		None, odd, or even
Stop bits when transmitting		1 when baud rate $\geq 300$ 2 when baud rate = 110 or 150
Receive		Receive either 1 or 2 stop bits transparently
Flow control		Hard, soft
Output terminators		CR, LF, or CR LF
Echo		On, off



Table 1-3. Communication Ports and Interfaces (cont.)

Characteristic	Performance Requirement		Supplemental Information	
	Pin	1450-1	1450-2	1450-3
Remote interface between TDC-10 and Tektronix 1450	1	N/C	N/C	Zero carrier
	2	N/C	N/C	Audio only 1
	3	N/C	N/C	Audio only 2
	4	N/C	N/C	Audio carrier loss 1
	5	N/C	N/C	Audio carrier loss 2
	6	Envelope detect	Envelope detect	Envelope detect
	7	Video loss open	Video loss open	Video loss open
	8	Video loss common	Video loss common	Video loss common
	9	Video loss closed	Video loss closed	Video loss closed

Table 1-4. Power Requirements

Characteristic	Performance Requirement	Supplemental Information
Input voltage	90 to 132 VAC or 180 to 250 VAC, 50/60 Hz auto ranging	
Input power	At 115 VAC, 60 Hz: 100 Watts, 150 VA maximum	
Fuse type		4 A, 250 V, Fast Blow

Table 1-5. Weights and Dimensions

Characteristic	Performance Requirement	Supplemental Information
Weight		37 lbs (17 kg)
Dimensions		21.7 x 19 x 3 1/2 inches (55.12 x 48.26 x 8.89 cm)

Table 1-6. Environmental Characteristics

Characteristic	Performance Requirement	Supplemental Information
Temperature	Operating: 0 to 50 °C Non-operating: -40 to 75 °C NVRAM not guaranteed to retain data at temperatures below 0 °C	
Altitude	Operating to 15,000 ft. Non-operating to 50,000 ft.	
Vibration (operating)	Resonant search from 5 - 55 Hz, 0.013" p-p displacement for 15 minutes in the 3 major axes. In each major axis, dwell for an additional 10 minutes at the frequency of the major resonance, or at 33 Hz if no resonance is found. Resonance is defined as 2X input displacement. Total vibration time is 75 minutes.	ICPM and spur performance are degraded by 2.1° peak at 0.01 in. displacement at resonance.
Shock (operating and non-operating)	Three guillotine-type shocks of 30g, one-half sine, 11 mS duration each direction along each major axis, total of 18 shocks.	
Electromagnetic compatibility		FCC Rules Part 15 Subpart J, Class A. Meets VDE 0871 Class B - regulations for RFI Suppression of High Frequency Apparatus and Installations. European Community Electromagnetic Compatibility Directive (Directive 89/336/EEC).

Table 1-7. Miscellaneous Characteristics

Characteristic	Performance Requirement	Supplemental Information
Standard accessories		Power cord TDC-10 interface 015-0649-00 Instruction manual 1450 remote cable BNC Cable SMA Cable TDC-10 interface cable Rack mount guide
Calibration period		12 months (compensates for reference oscillator drift)



# Section 2

## SETUP AND OPERATION

Setup consists of connecting the TDC-10 Tunable Down Converter to the 1450 Television Demodulator, applying power, and configuring. Operation includes tuning channels selected from a channel table and viewing information about each tuned channel on the TDC-10 display. The TDC-10 converts a video-modulated input RF signal to a modulated intermediate frequency and sends it to a 1450 demodulator.

This section describes the following topics:

- Unpacking
- Connection and power up
- Controls, displays, and indicators
- Configuration
- Operation

### UNPACKING THE INSTRUMENT

Open the shipping container and remove the TDC-10, TDC-10 interface module, power cord, and signal cables. Save the shipping container and packing materials for repacking in case it becomes necessary to ship the instrument. If you are returning the instrument to the factory, see the customer service information in *Section 6: Maintenance and Troubleshooting*.

### CONNECTION AND POWER UP

In normal operation, the TDC-10 and a 1450 demodulator are stacked with the TDC-10 beneath the demodulator. The signal cables supplied with the TDC-10 are sized to length for this setup.

#### CAUTION

*The 1450 demodulator and the TDC-10 must be powered down before you attempt to connect them. Attempting to connect either instrument with power applied can damage sensitive electrical components.*

Follow these steps to connect and power up the TDC-10 Tunable Down Converter (see Figure 2-1). The TDC-10 data and signal ports are described in the appendix.

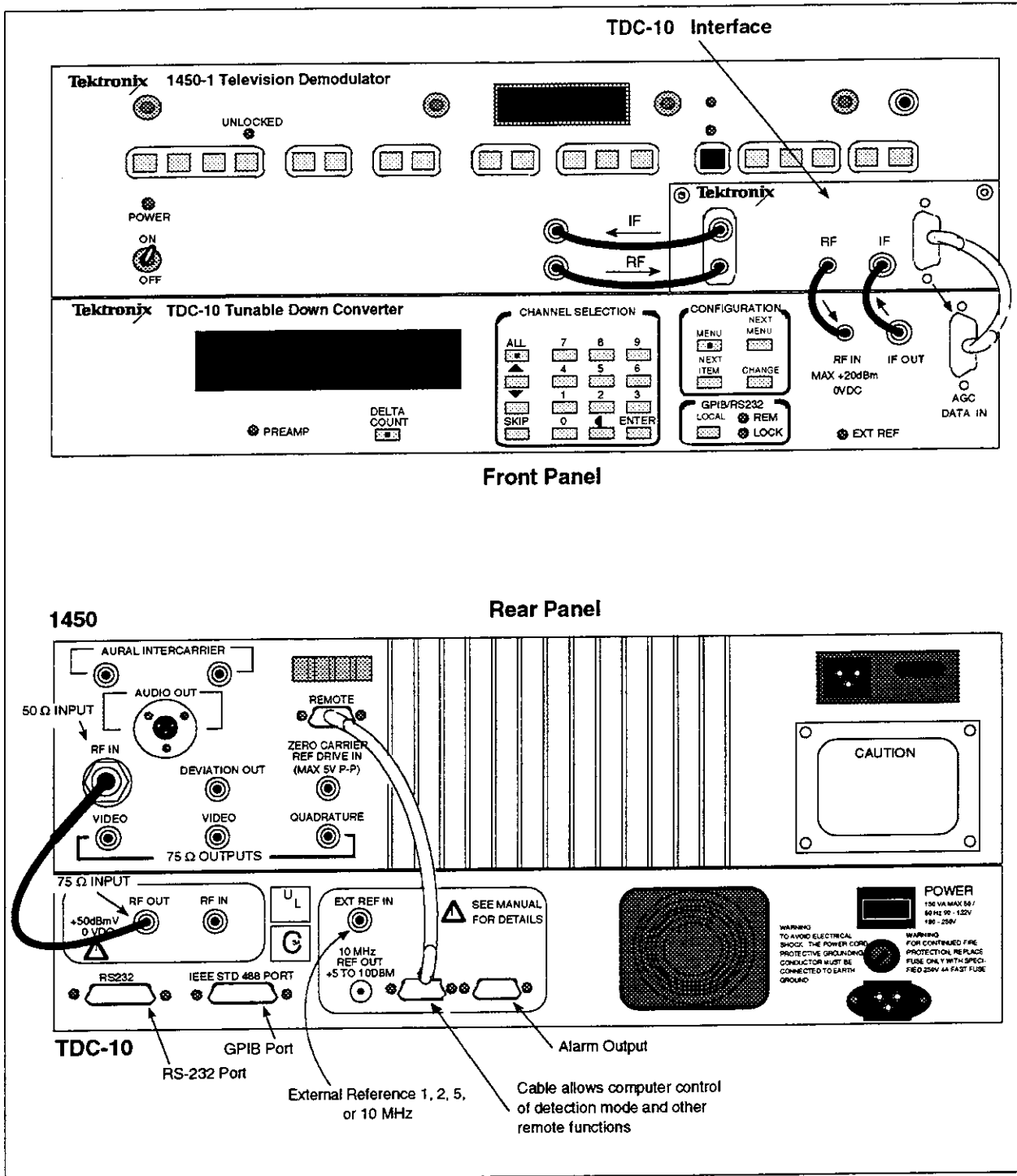

Figure 2-1. Front- and rear-panel cable connections (shown for 75 Ω systems).

1. Position the TDC-10 and 1450 demodulator as described.
2. Connect a 50 Ω RF input source to the demodulator's RF In connector.

**NOTE**

*If yours is a 75  $\Omega$  RF input source, connect it to the 75  $\Omega$  In BNC connector on the TDC-10 rear panel. Then, using a BNC-to-BNC cable and BNC-to-N adaptor (or a BNC-to-N cable), connect the TDC-10's 50  $\Omega$  Out to the demodulator's 50  $\Omega$  In connector.*

3. Plug the TDC-10 interface module into the demodulator front-panel slot and tighten the thumbscrews.
4. Connect the special 9-pin AGC data cable (Tektronix part 174-2884-00) between AGC Data Out on the TDC-10 interface module and AGC Data In on the TDC-10 front panel.
5. Connect the 50  $\Omega$  BNC cable (Tektronix part 012-0751-00) between IF In on the TDC-10 interface module and IF Out on the TDC-10.
6. Connect the 50  $\Omega$  SMA cable (Tektronix part 012-0752-00) between RF Out on the TDC-10 interface module and RF In on the TDC-10.
7. Connect a 50  $\Omega$  SMA cable (same cable as in step 6, but supplied with the 1450 demodulator) between RF In on the TDC-10 interface module and RF Out on the demodulator.
8. Connect a 50  $\Omega$  BNC cable (same cable as in step 5, but supplied with the 1450 demodulator) between IF Out on the TDC-10 interface module and IF In on the demodulator.
9. Connect the 1, 2, 5, or 10 MHz external reference (if used) to the Ext Ref In BNC connector on the TDC-10 rear panel.
10. Connect RS-232 or GPIB remote control data cables, if used.
11. Connect a remote data cable (Tektronix part 174-2885-00) between Remote Out on the TDC-10 and Remote on the demodulator (this connection allows access to 1450 demodulator control functions via the TDC-10's GPIB or RS-232 interfaces).
12. Connect the line power cord to the power input connector on the TDC-10 rear panel.
13. Apply power to the TDC-10 and the demodulator.

**CONTROLS, DISPLAYS, AND INDICATORS**

The general organization of the front panel is shown in Figure 2-2. This section describes front-panel features.

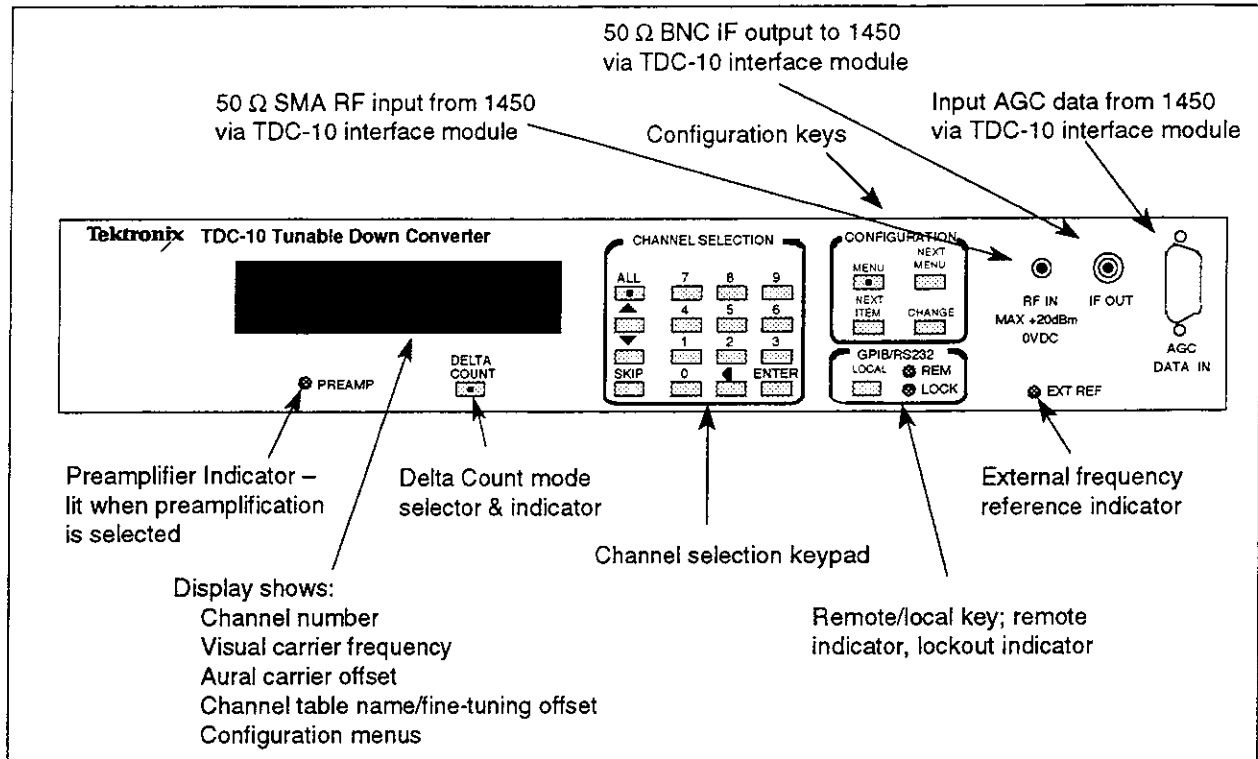

Figure 2-2. Front-panel layout.

## Display

At power up and during normal operation, the TDC-10 display shows the following:

- Channel number
- Channel table name (in Fine Tuning mode, shows fine-tuning offset)
- Video carrier frequency
- Audio carrier offset frequency

The example display shown in Figure 2-3 is a typical operating-mode display. The following paragraphs describe each display field.



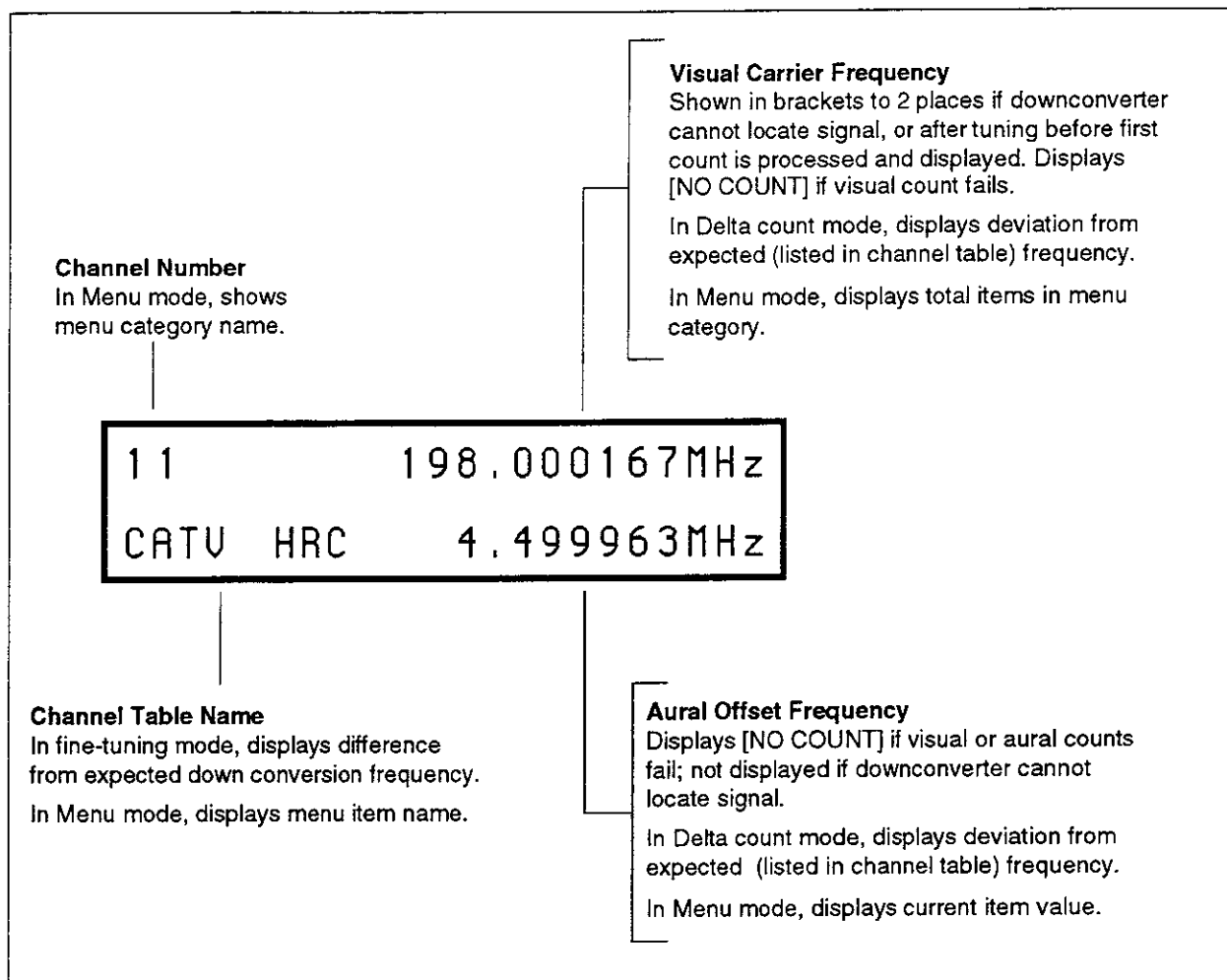

**Figure 2-3. Downconverter display in normal operation.**

**Channel number field** — displays the number of the current down-converted channel. When you enter a channel number with the channel selection keys, this field displays the numbers you enter.

**Channel table name field**— displays the name of the currently selected channel table. The TDC-10 contains several built-in channel tables, including: B'Cast, CATV-STD, CATV-HRC, CATV-IRC, Eur-BG, Eur-I, Japan-M, and China-DK. In Fne Tuning mode (described later in this section), this field displays the change in frequency from the frequency defined in the channel table. Channel tables and their contents are listed in the appendix.

**Visual carrier frequency field** — displays the video carrier frequency. In Delta Count mode (described later in this section) this field displays the difference between measured and expected (from the channel-table listing) video carrier frequencies.

**Aural carrier offset field** — displays the audio carrier offset frequency. In Delta Count mode this field displays the difference between measured and expected audio carrier offset frequencies.

When the TDC-10 is unable to locate an input signal, the audio carrier offset display changes to [No Count] and the video frequency is displayed to two decimal places in brackets.

#### **NOTE**

*If a video carrier is present but the audio carrier is missing, the TDC-10 may count noise and display an invalid audio offset frequency.*

## Controls

The front-panel controls consist of a series of keys that let you perform TDC-10 operational functions. These keys are organized into the following functional groups:

- Counter mode
- Channel selection
- Configuration keys
- Remote control

The following paragraphs describe the front-panel controls.

### COUNTER MODE

The TDC-10 may be toggled between Delta Count and true-count modes. In true-count mode, the TDC-10 displays the frequency of the input RF signal.

When you press DELTA COUNT, the TDC-10 enters Delta Count mode (the DELTA COUNT LED lights). In this mode, the TDC-10 displays the difference between actually counted and expected (listed in the channel table) frequencies.

### CHANNEL SELECTION

The TDC-10 can be tuned to the desired channel by entering the channel number (up to three digits — additional digits are ignored) and pressing ENTER. If you make a mistake entering a channel number, just press the backspace key one or more times and re-enter the correct numbers. Backspacing all channel digits causes the display to show the originally selected channel. See Figure 2-4.

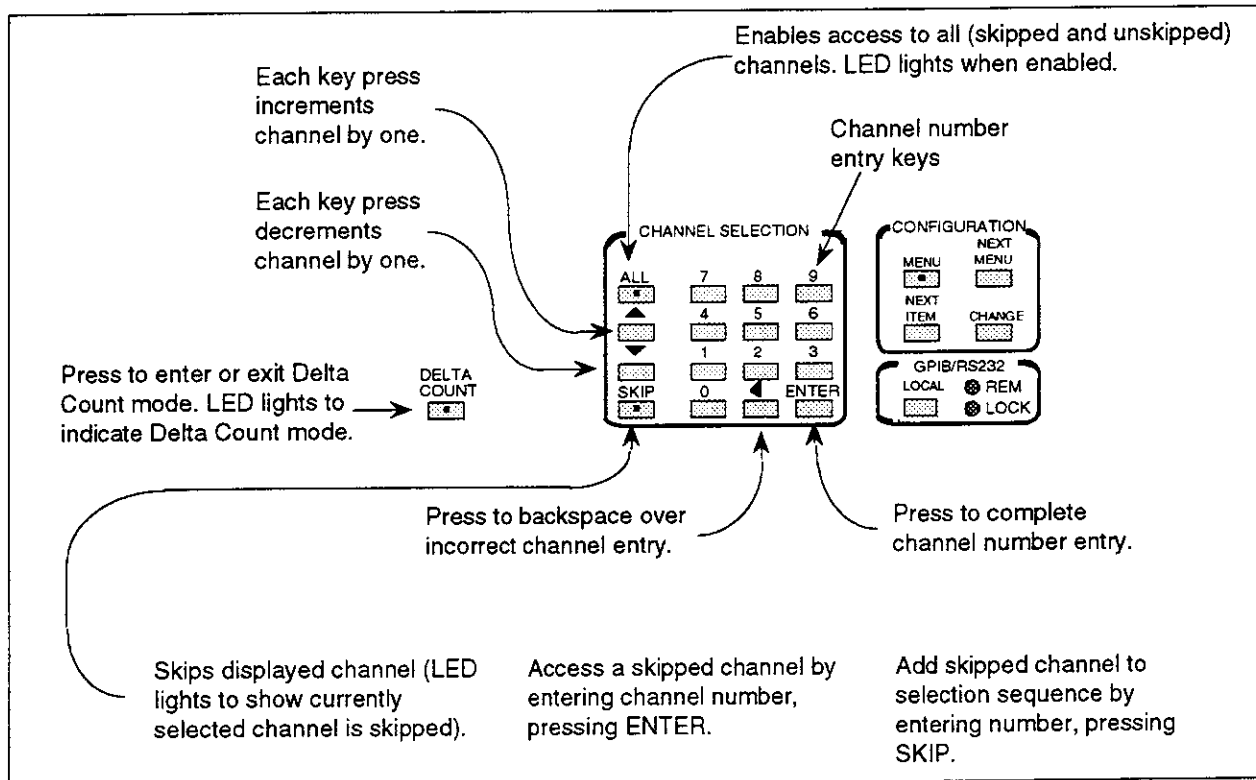

Figure 2-4. Channel selection keypad.

You may also select the next or previous channel in the current channel table by pressing the up- or down-arrow keys. Each key press increments or decrements the channel number by one table entry. Channel selection is circular (at the end of the channel table, selecting the next higher channel automatically selects the first channel in the table; at the beginning of the channel table, selecting the next lower channel automatically selects the last channel).

If you want to skip a channel during up/down operation, you can remove it from the selection sequence by pressing SKIP. This causes the TDC-10 to bypass the skipped channel and access the next available channel in the table.

**NOTE**

*If all channels in a table are skipped, the TDC-10 continues to display the last channel in the table. The TDC-10 must have at least one channel listed in a channel table.*

You may access a skipped channel by entering the channel number with the keys and pressing ENTER (accessing a skipped channel lights the SKIP LED). You may add the skipped channel to the selection sequence again by entering the channel number and pressing SKIP.

You may access all skipped channels by pressing ALL. In this mode, all channels can be accessed with the up- or down-arrow keys (accessing all channels lights the ALL LED).

**CONFIGURATION KEYS**

Downconverter configuration is via a series of menus. You may access and change these menus with the four configuration keys described in Figure 2-5.

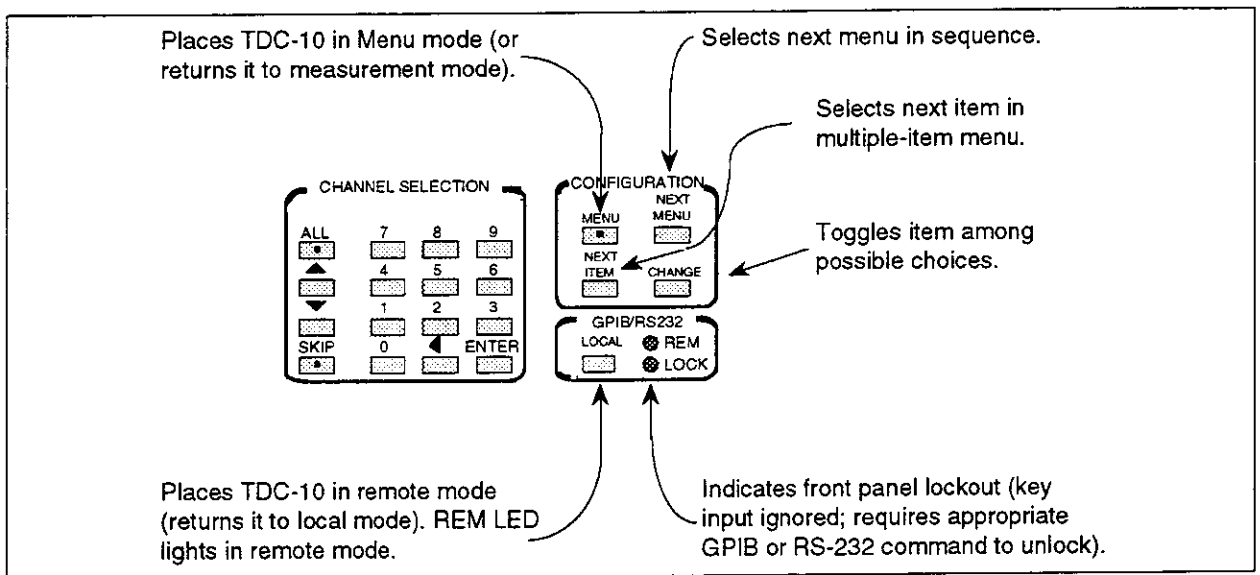

**Figure 2-5. Configuration keypad.**

**MENU** — Places the TDC-10 into Menu mode (the MENU LED lights). Pressing the key again returns the TDC-10 to operating mode.

**NEXT MENU** — Selects the next menu in the list.

**NEXT ITEM** — Selects the next item in a multiple-item menu. For example, the Tuning menu contains five items.

**CHANGE** — Toggles the displayed menu item through the available choices.

## REMOTE CONTROL

The TDC-10 allows remote control of its functions via RS-232 and GPIB communications ports. In remote mode (the instrument ignores front-panel input), only the LOCAL key is active. Pressing the LOCAL key returns the instrument to local mode (the instrument accepts front-panel input). You may configure the TDC-10 for remote operation via selections in the GPIB or RS-232 menus. See *Section 3: Remote Operation* for information about controlling the TDC-10 remotely.

## Indicators

The TDC-10 front panel contains several LED indicators (LEDs associated with control keys were described earlier). The functions of these are described below.

**PREAMP** — The TDC-10 furnishes two menu-selectable levels of input signal preamplification. Selecting either preamplification level lights this LED.

**REM** — Placing the TDC-10 in remote mode (via a remote command from a controller) lights this LED.

**LOCK** — In remote mode the TDC-10 can have all front-panel keys (including the LOCAL key) locked out via a local lockout command from a controller. Locking out the front panel lights this LED.

**EXT REF** — This LED lights when the TDC-10 senses an applied 1, 2, 5, or 10 MHz external reference signal. When an external reference signal is first detected by the instrument (one or two seconds after the reference signal is connected or several seconds after power up), the EXT REF LED begins blinking. After the instrument has phase locked all internal signals to the external reference signal (this takes about one minute), the LED lights steadily. If the external reference is disconnected, the instrument shuts off the LED within one or two seconds.

## CONFIGURATION

Configuration tasks are those that are performed only occasionally, rather than frequently while using the instrument. Configuration tasks include setting display intensity and selecting an output intermediate frequency. These tasks are described below.

### Setting Display Intensity

The TDC-10 display intensity may be adjusted to any of four levels for optimum visibility in a variety of ambient lighting conditions. Follow these steps to adjust the display intensity.

1. Press MENU, then press NEXT MENU one or more times to display the Display menu.
3. Press CHANGE to select the desired display intensity (the intensity changes to the new value when you select it).
4. Press MENU to return the TDC-10 to operating mode.

### Selecting an Output IF

You may select any of four output intermediate frequencies: 37.0, 38.0, 38.9, and 45.75 MHz. The one you select depends on the IF input required by the 1450 demodulator used with your TDC-10. Follow these steps to select an output IF.

1. Press MENU, then press NEXT MENU one or more times to display the first Tuning menu item (1 of 4).
2. Press NEXT ITEM twice to display the output IF menu item (3 of 4).
3. Press CHANGE one or more times to select the desired output IF and confirm the change when requested to do so.

4. Press MENU to return the TDC-10 to operating mode.

## OPERATION

Typical TDC-10 operation includes tuning channels selected from a channel table and viewing information about each tuned channel on the TDC-10 display. The TDC-10 converts the incoming video-modulated RF signal into a modulated IF signal which is sent, via the IF Out connector, to the 1450 demodulator for further processing. Other TDC-10 tasks include measuring and displaying video carrier frequencies and audio carrier offset frequencies.

Downconverter functions can also be controlled remotely via the GPIB or RS-232 ports. For information about remote control operations, see *Section 4: Remote Operation*.

This section describes typical TDC-10 operations.

### Selecting a Channel Table

A channel table contains information about each channel in a video broadcast allocation standard. Information contained in a channel table includes:

- Channel table name
- Audio carrier offset frequency
- List of channels in the broadcast allocation

For each channel on the list the table also contains the channel number, its frequency, and whether or not the channel is skipped when the TDC-10 is tuned.

The TDC-10 contains channel tables for several channel allocation standards. See the appendix for channel table information.

Tuning the TDC-10 to a channel in a specific channel allocation standard requires that you first select the appropriate channel table. Follow these steps to select a channel table.

1. Press MENU, then press NEXT MENU one or more times to display the first Tuning menu (1 of 4).
2. Press CHANGE one or more times to select the desired channel table.
3. Press MENU to return the TDC-10 to operating mode.

You should see the name of the selected channel table on the lower-left section of the display.

### Fine Tuning the Conversion Frequency

After selecting an appropriate channel table you may tune the TDC-10 to a specific channel by entering the channel number. You may also tune a channel with the up- or down-arrow keys. Channel tuning is discussed in *Channel Selection*.

If desired, you may fine tune the down conversion frequency 50 kHz at a time. Follow these steps to enable fine tuning.

1. Press MENU, then press NEXT MENU one or more times to display the first Tuning menu item (1 of 4).
2. Press NEXT ITEM to display the Fine Tuning menu item (2 of 4).
3. Press CHANGE to enable fine tuning (the display changes from Off to On). Pressing CHANGE a second time disables fine tuning.
4. Press MENU to return the TDC-10 to operating mode.

In Fine Tuning mode, the channel table name field in the display becomes a fine-tuning indicator and the up- and down-arrow keys control fine tuning instead of changing the channel number. Each key press raises or lowers the down conversion frequency by approximately 50 kHz.

You may select another channel with the channel selection keys while in Fine Tuning mode, but doing so removes all fine tuning (sets it to zero) when the TDC-10 accesses the new channel. The skip and all functions operate normally.

In Fine Tuning mode, channel increment and decrement functions (the up- and down-arrow key functions) are available via the remote interfaces.

To exit FineTuning mode, follow the steps above and toggle Fine Tuning to Off.

### Selecting Preamplification

The TDC-10 offers two selectable input RF gain stages of approximately 17 and 27 dB. You may select either of these preamplification stages to improve instrument sensitivity when measuring low level signals. Input RF preamplification (or attenuation) should be selected according to the following criteria:

Input Signal Level	Optimum Signal Level <sup>1</sup>	Preamp or Pad
-44 — 22 dBmV	-3 — 9 dBmV	27 dB preamp
-34 — 32 dBmV	9 — 23 dBmV	17 dB preamp
-17 — 49 dBmV	23 — 47 dBmV	0 dB preamp
-7 — 59 dBmV	47 — 57 dBmV	10 dB pad
3 — 69 dBmV	57 — 67 dBmV	20 dB pad
13 — 79 dBmV	67 — 77 dBmV	30 dB pad

<sup>1</sup> For best signal-to-noise ratio and minimum distortion.

Follow these steps to select preamplification.

1. Press MENU, then (if necessary) press NEXT MENU one or more times to display the input menu.
2. Press CHANGE to select the desired preamp gain (continuously pressing CHANGE toggles the preamplifier between 0, ~17, and ~27 dB).
3. Press MENU to return the TDC-10 to operating mode.

Selecting any preamplifier gain other than 0 dB (no gain) lights the PREAMP LED.



*Selecting an incorrect preamp range or pad value for the input RF signal level can cause erroneous measurement results.*

### Tuning Lockout

Tuning lockout prevents accidental or unauthorized tuning. When tuning lockout is enabled, the TDC-10 ignores any input associated with tuning and displays this message:

Cannot tune while in Tuning Lockout mode

Input that causes this message to be displayed includes attempts to select a channel, change channel tables, select a new output IF, or fine tune the instrument.

Follow these steps to enable tuning lockout.

1. Press **MENU**, then press **NEXT MENU** one or more times to display the first Tuning menu item (1 of 4).
2. Press **NEXT ITEM** several times to display the Tuning Lockout menu item (4 of 4).
3. Press **CHANGE** to enable tuning lockout (the display changes from Off to On). Press **CHANGE** again to disable tuning lockout and confirm the change when requested to do so.
4. Press **MENU** to return the TDC-10 to operating mode.





# Section 3

## REMOTE OPERATION

The TDC-10 Tunable Down Converter allows remote control of its functions via RS-232 and GPIB communications ports. With a desktop computer and appropriate software, you can acquire, transfer, process, and analyze data remotely.

The TDC-10 GPIB interface conforms to IEEE Standards 488.1-1987, 488.2-1987, and Tektronix Standard Codes and Formats 1991. All Tektronix codes and formats, mandatory commands, and several optional commands are supported.

The command set and message structure are almost identical for GPIB and RS-232 interfaces. However, a few interface-specific considerations, such as communications parameters and protocols, are different. The setup for each interface is described separately in this section.

### NOTE

*GPIB operation is discussed in the following section. RS-232C operation is discussed later in the section titled Operation over the RS-232C Interface.*

This section describes how to operate the TDC-10 Tunable Down Converter remotely via its GPIB or RS-232 interfaces. The section lists the hardware and software needed and describes how to configure the TDC-10 for remote operation. The section also lists and describes the TDC-10 remote control command set.

## GPIB OPERATION

In addition to conformance with the IEEE 488.2 standard, the TDC-10 conforms to the Tektronix Interface Standard for GPIB Codes, Formats, Conventions, and Features. This standard promotes ease of operation and — so far as possible — makes the TDC-10 compatible with other Tektronix instruments and with GPIB instruments from other manufacturers.

The IEEE 488.2 standard establishes electrical levels, connector configuration, and signal protocols for communication between two or more electronic instruments using a common multi-line bus structure. The bus structure, known as the General Purpose Interface Bus (GPIB), consists of eight data lines, eight dedicated control signal lines, a shield, and various grounds.

Instruments connected to the bus are designated as talker, listener, or both talker and listener. A listener can only receive information over the bus and a talker can only send information. A talker and listener can do both, but not simultaneously.

One instrument is usually designated as the system controller. This is generally a computer that determines through software when specific instruments are activated as talkers or listeners. Each instrument is assigned a unique address between 0 and 30, but only 15 instruments can be connected to the bus at one time.

The following subsections describe how to set up the TDC-10 for GPIB operation.

## Operation over the GPIB

You need the following equipment to operate the TDC-10 over the GPIB:

- TDC-10 Tunable Down Converter connected to a 1450 Television Demodulator
- System controller
- Interconnecting cable
- Software device driver
- Application software

### System Controller

The system controller can be any general-purpose computer equipped with a GPIB board. Specially built controllers can also be used, but these are beyond the scope of this manual. The techniques discussed here are appropriate to the IBM family of personal computers (PCs) and their function-alike counterparts, which support the MS-DOS, PC-DOS, or OS/2 environments.

To function as a controller, your computer must be equipped with a GPIB board. Tektronix supplies a National Instruments GPIB board suitable for the purpose. Contact your Tektronix sales office for more information.

The GPIB board is supplied with device driver software and documentation that describes installing and configuring the board and software. The documentation also describes the general use of GPIB commands.

### Software Device Driver

The device driver is a program (usually supplied with the GPIB board) that allows your computer to access the board. An additional program is usually supplied that enables you to correctly configure the driver by providing information such as instrument address and type of message terminator.

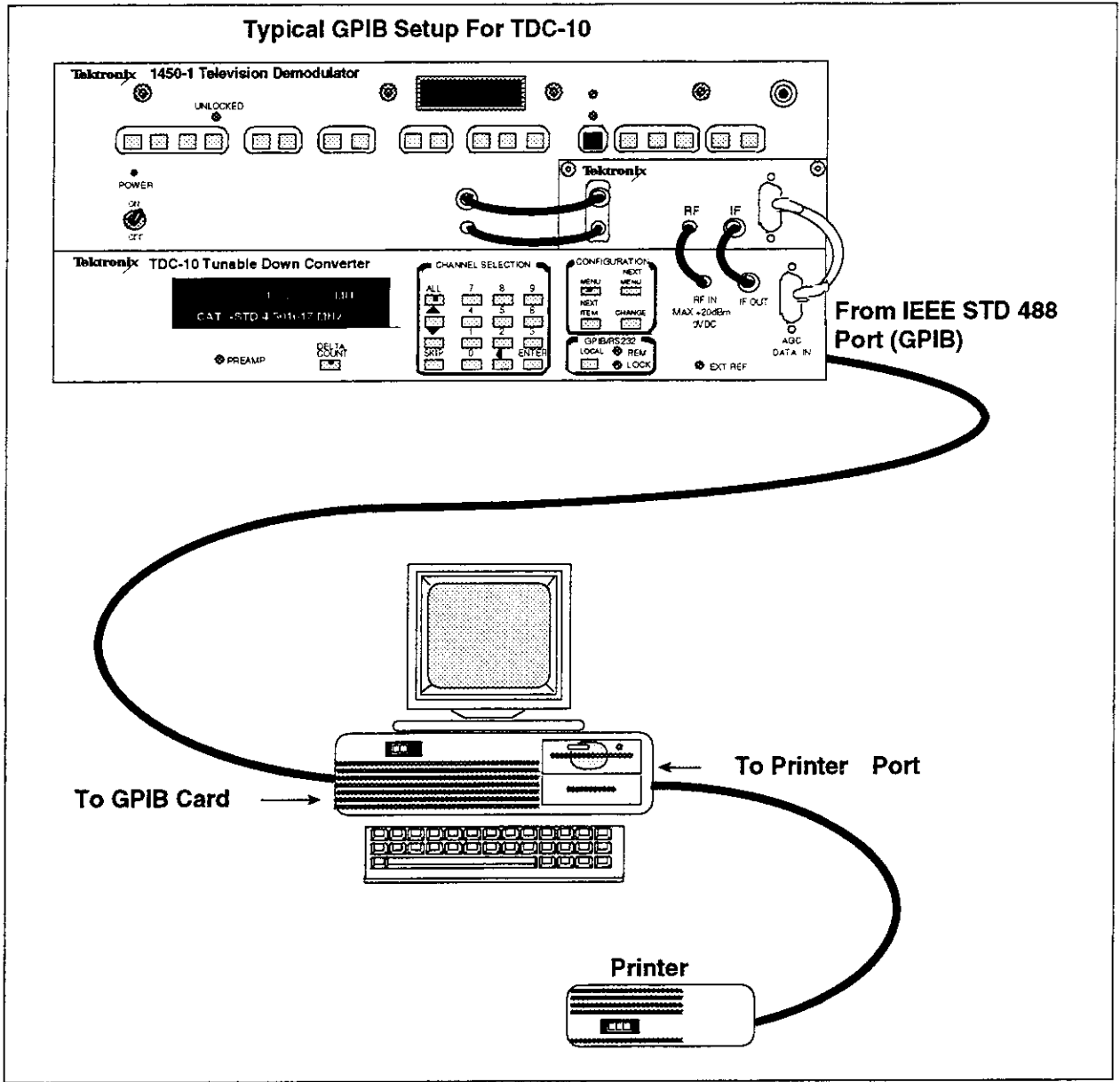

Figure 3-1. Typical Small Instrument System for GPIB.

### Interconnecting Cable

An appropriate interconnect cable is required to connect the controller to the TDC-10. The cable is supplied as part of the Tektronix PC-GPIB application software package, or it may be purchased separately from Tektronix. Contact your Tektronix sales office for more information.

### NOTE

*PC-GPIB consists of a National Instruments GPIB card, cable, and driver software. Contact your Tektronix sales representative for more information.*

## Application Software

Application software is the program or programs that control and acquire data from the TDC-10. You can construct your own programs or use an application software package such as PC-GPIB, but you will need the applications interface software supplied by the GPIB board manufacturer.

## SETTING UP FOR GPIB OPERATION

Your equipment must be correctly configured before GPIB operations can be performed. The following tasks must be completed.

- Install cables between the system components
- Configure the TDC-10
- Configure the device driver and install it into controller memory

This section describes the first two tasks in detail. Refer to the documentation that accompanies your controller's GPIB interface board for device driver configuration and installation information.

## Connecting the Equipment

If your system consists of a controller and TDC-10, you can simply connect one end of the interconnecting cable to each instrument. A star configuration, daisy chain configuration, or combination of these should be used when more than two instruments are on the bus. Up to 15 instruments can be connected.

### CAUTION

*To maintain electrical performance of the GPIB bus, use no more than 2 meters of cable times the number of connected devices, whichever is less. Use caution with single-cable lengths of 4 meters or more. Ensure that at least two-thirds of the connected instruments are powered on.*

## Configuring the TDC-10

Apply power to the TDC-10 and press the NEXT MENU button one or more times until the GPIB menu appears. It should look like Figure 3-2. This is the first of two menus that you may use to perform these GPIB functions:

- Placing the instrument on or off line
- Setting the GPIB device address

### PLACING THE TDC-10 ON LINE

Press the CHANGE button to place the TDC-10 on line (consecutive presses of the CHANGE button toggles the GPIB status between off line and on line). When placed on line, the TDC-10 is ready to receive GPIB commands and queries and provide responses.

GPIB Menu	1 of 2
Status =	Off Line

Figure 3-2. The GPIB Status menu.

## SETTING THE GPIB DEVICE ADDRESS

Press the NEXT ITEM button to display the GPIB Address menu (consecutive presses of the NEXT ITEM button toggles between GPIB status and GPIB Address menus). Now, press the CHANGE button to assign a GPIB address (each press of the CHANGE button advances the GPIB address one number). The address can have a value of 0 to 30. However, address 0 is usually reserved for system controllers.

The address you assign is not critical, but it should not be the same address used for any other instrument on the bus.

### NOTE

*You must assign the same GPIB address to the TDC-10 that was used when configuring the controller device driver (software D0).*

If the TDC-10 is the only instrument on the bus, we suggest using 1 as the address. The address you set is read by the TDC-10 and retained in non-volatile memory.

GPIB Menu	2 of 2
Address =	1

Figure 3-3. The GPIB Address menu.

## Configuring the Device Driver

Refer to the documentation accompanying your controller's GPIB board for information on configuring the device driver.

## Communicating With the TDC-10

The GPIB enables remote or automated control of instruments on the bus, in this case, a tunable television downconverter. An application program (often called a test, measurement, or control program) determines TDC-10 operations by exchanging messages with the TDC-10. The messages can be of the generic GPIB type, or they can be instrument specific.

Generic messages are usually carried out by GPIB hardware and the GPIB device driver without intervention by the operator or programmer. They typically implement routine housekeeping chores such as instrument addressing, handshaking, requesting service, or terminating messages.

The instrument-specific messages are also referred to as device-dependent messages. They are generally understood by, and meaningful to, only the instrument or class of instruments for which they are designed. The organization and description of instrument-specific messages is explained later in this section.

The TDC-10 is addressed as a talker or listener to send or receive messages, depending on whether messages are being sent to or received from the system controller. The GPIB system software provided with your GPIB card automatically addresses the TDC-10 as a talker or listener depending on the application software. The device-dependent messages are then transferred between the controller and the TDC-10 over the GPIB as one or more eight-bit bytes of information.

## Preparing the Software

After completing the set up procedures your equipment is ready for GPIB operation, but you must still provide the application software needed to control the TDC-10.

## RS-232 OPERATION

Skip this section if you plan to use the GPIB interface to control the TDC-10.

The TDC-10 RS-232 interface follows the EIA Standard RS-232-D. EIA Standard RS-232-D revises RS-232C so it conforms with international standards CCITT V.24, V.28 and ISO IS2110. This standard establishes electrical levels, connector configuration, and signal protocols for communication between two devices called the DCE (data circuit-terminating equipment) and the DTE (data terminal equipment). The TDC-10 implements the DTE end of the interface.

### NOTE

*The RS-232 interface is not a bus. Only one device can be connected to the instrument's RS-232 interface. Unlike a GPIB interface, RS-232 does not support device addresses or serial polling.*

The downconverter RS-232 interface requires a minimum of three lines for operation.

- Transmit data (TXD)
- Receive data (RXD)
- Ground (GND)

If hardware handshake is required, two additional lines must be supplied in the cable.

- Clear to Send (CTS)
- Request to Send (RTS)

The section entitled *Selecting a Data Flow Control Method*, located later in this section, describes the use of these lines for hardware flow control.

EIA Standard RS-232-D defines other lines typically used for modem control and handshaking. The TDC-10 can operate using the minimum wiring configuration. See the appendix for RS-232 connector wiring information.

Data bits are transferred serially, one bit at a time, over the interface. Data consists of instrument commands and queries, control settings, parameter values, or display information.

If a computer is connected to the downconverter via the RS-232 interface, the computer's serial interface (called a COM port if the controller is an MS-DOS device) must be correctly configured beforehand. Programmed commands and data can then be transmitted over the interface to the instrument.

If a query such as `FETCH:FREQ?` is transmitted, the TDC-10 formats its response immediately and sends it back to the computer. The control program must be ready to receive the incoming data. The following subsections describe how to set up the TDC-10 for RS-232 operation.

## OPERATION OVER THE RS-232 INTERFACE

The following items are needed to operate the TDC-10 Tunable Down Converter over the RS-232 interface:

- System controller or terminal
- Software device driver
- TDC-10 Tunable Down Converter and 1450 Television Demodulator
- Interconnecting cable
- Application software

Figure 3-4 shows a typical RS-232 system configuration. The illustration shows a computer (PC) controlling the downconverter via the RS-232 interface, with a printer connected to the computer over a Centronics interface.

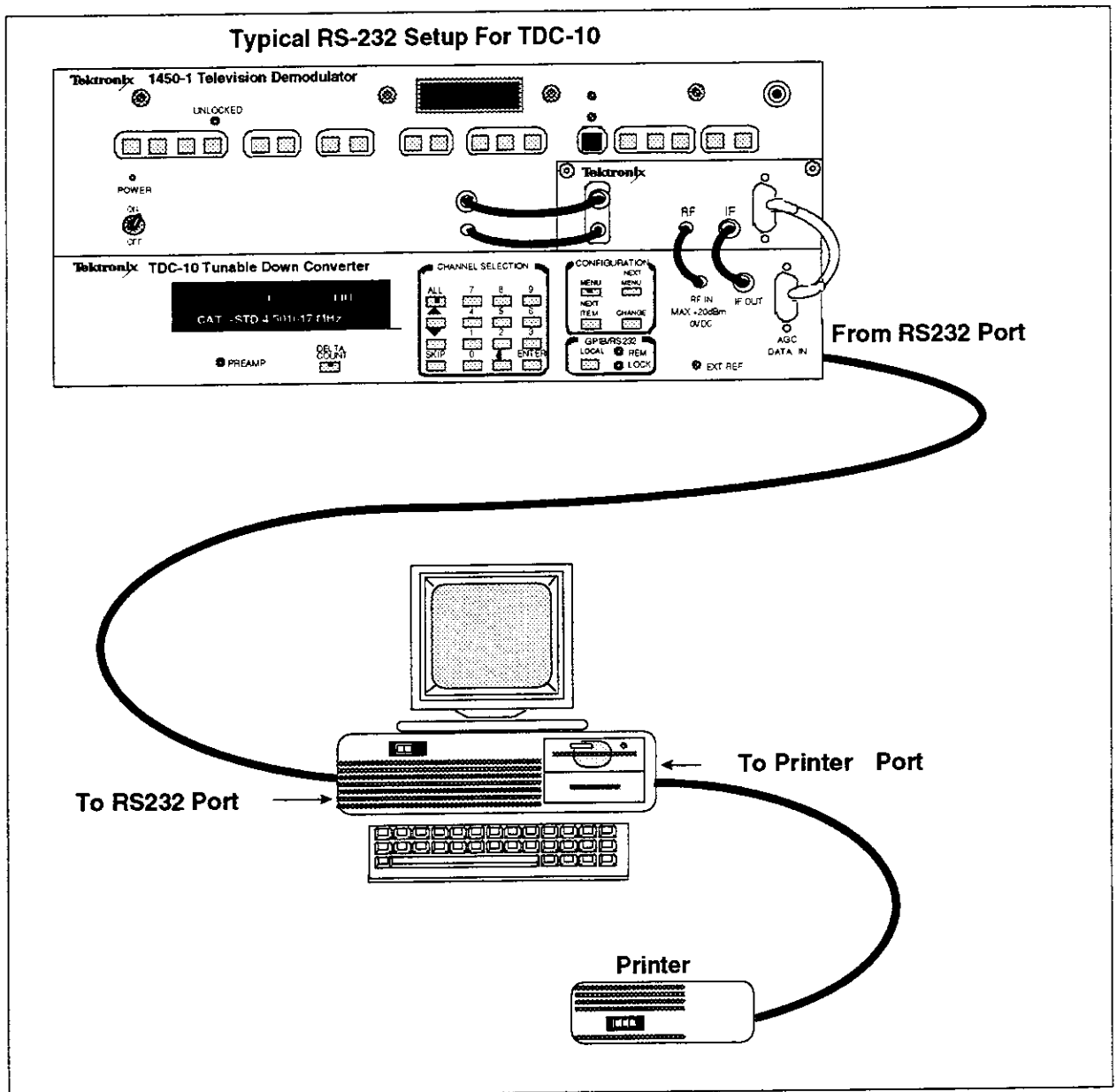

Figure 3-4. RS-232 System Configurations.

## System Controller

The system controller can be any general-purpose computer or terminal equipped with an RS-232 interface (also called a COM port or serial interface). Specially built controllers can be used, but are beyond the scope of this manual. The techniques and programs discussed in this manual are appropriate to the IBM PC family of computers and their function-alike counterparts, which support the MS-DOS, PC-DOS, or OS/2 environments.

## Software Device Driver

The device driver is a program that handles input and output to the RS-232 interface on your computer. The driver for your system depends on the operating system and the programming

language you are using. For example, if you are operating a PC, the RS-232 driver configuration may be set with the MS-DOS MODE command. If your control program is written in the BASIC or QuickBASIC language, optional arguments in the OPEN statement can supply RS-232 configuration settings.

## Interconnecting Cable

An appropriate cable is required to connect between the controller and the TDC-10. The pinout and connector type are identical to the 25-pin connector used for PC type RS-232 interfaces. Such cables are available in most computer stores. For some RS-232 devices, null-modem adapters are needed.

## Application Software

Application software is the program or programs that control and acquire data from the TDC-10. You can construct your own application programs using an application utility such as PC-GPIB (available from Tektronix). Off-the-shelf software is also available.

## SETTING UP FOR RS-232 OPERATION

Your equipment must be correctly configured before performing RS-232 operations. The following tasks must be completed.

- Install cables between the system components
- Configure the TDC-10
- Configure the controller application software

This section describes the three tasks.

### Connecting the Equipment

Only one device (computer, plotter, or printer) can be attached to the downconverter's RS-232 interface. For systems consisting of a controller and the downconverter, you can simply connect one end of the interconnecting cable to each device. Figure 3-4 shows a typical configuration.

### Configuring the TDC-10

Both devices (the controller and downconverter) in an RS-232 system must be configured the same way. Before configuring the downconverter, be sure to check the configuration parameters for the device with which you expect to communicate.

Apply power to the TDC-10 and press the MENU button to place the instrument in Menu mode (the green LED on the MENU button lights). Now, press the NEXT MENU button one or more times to display the RS232 menu (see Figure 3-4). This is the first of six menus that you may use to set these RS-232 parameters:

- Instrument on or off line
- Baud rate
- Parity
- Flow control
- Output termination
- Echo mode



RS232 Menu	1 of 6
Status =	Off Line

**Figure 3-5. First RS-232 port configuration menu.**

You may move through the six RS-232 menus by pressing the NEXT ITEM button. The remaining paragraphs of this section describe how to configure the RS-232 parameters.

### CAUTION

*Changes to GPIB or RS-232 remote communications parameters take effect immediately. Before making changes to these parameters, verify that the downconverter's remote communications ports are not in use.*

### NOTE

*The downconverter's RS-232 port supports 7-bit ASCII data transfers only. Eight-bit (binary) transfers are not supported.*

## PLACING THE TDC-10 ON LINE

With the RS-232 Status menu displayed, press the CHANGE button to place the downconverter on line (press the CHANGE button again to move it off line). With status set to Online, the TDC-10 is ready to receive commands and queries and provide responses via its RS-232 port. Figure 3-5 shows the RS-232 Status display.

When the status is set to Offline, the RS-232 interface is ignored; data is neither received nor transmitted.

## SETTING THE BAUD RATE

Press the NEXT ITEM button to display the Baudrate menu. This menu determines the data transfer baud rate for RS-232 communications (see Figure 3-6).

RS232 Menu	2 of 6
Baudrate =	9600

**Figure 3-6. RS-232 baud rate display.**

To select a baud rate, repeatedly press the CHANGE button until the baud rate you desire is displayed. Baud rates ranging between 110 and 9600 are available.

The number of stop bits used is automatically selected by the downconverter when you change baud rates. Two stop bits are selected if the baud rate is 110 or 150; one stop bit is selected for all other baud rates.

## SETTING PARITY

Press the NEXT ITEM button to display the Parity menu. This menu determines whether odd, even, or no parity is used for data checking (see Figure 3-7). The default is None.

```

RS232 Menu      3 of 6
Parity =        None

```

Figure 3-7. RS-232 Parity display.

To change the parity selection, press the CHANGE button until the desired parity (Odd, Even, or None) is selected.

### SELECTING A DATA FLOW CONTROL METHOD

Press the NEXT ITEM button to display the Flow Control menu. This menu lets you select between three flow control methods: Soft, Hard, or None (see Figure 3-8). An explanation of each follows.

```

RS232 Menu      4 of 6
Flow Control =  None

```

Figure 3-8. RS-232 Flow Control display.

**Soft** — When the downconverter sends data through the interface and soft flow control is enabled, CTRL-S (ASCII 19, same as pressing CTRL and [S] simultaneously) halts the data stream until CTRL-Q (ASCII 17) is received. Any other character received in the interim is ignored. This type of flow control can be used with a 3-wire setup because additional handshake lines are not needed.

When Soft flow control is selected, the downconverter sends CTRL-S when its input data buffer is within 50 characters of being full (input buffer size is 512 bytes). It sends CTRL-Q when the buffer empties to the point at which additional characters can be safely accepted (less than 50 characters remain in the buffer). When its input buffer becomes full, any data sent to the downconverter is ignored.

**Hard** — When Hard flow control is selected, the downconverter sends data as long as the CTS (Clear-To-Send) line is TRUE and halts the data stream if CTS goes FALSE. Additional handshake lines (more than a 3-wire RS-232 implementation) are required to support Hard flow control.

When receiving data and Hard flow control is selected, the downconverter asserts RTS (Request-To-Send) TRUE until the input buffer is within 50 characters of being full. It then sets RTS FALSE. As with Soft flow control, when its input buffer becomes full, any data sent to the downconverter is ignored.

**None** — No flow control is used.

### SETTING OUTPUT TERMINATION

Press the NEXT ITEM button to display the Output Termination menu. This menu selects the EOL (end-of-line) indicator used to terminate messages sent over the downconverter's RS-232 interface. See Figure 3-9. The terminator can be CR (carriage return, ASCII 13), LF (line feed, ASCII 10), or CR LF (carriage return followed by line feed). To change the EOL status selection, press the CHANGE button until CR, LF, or CRLF is displayed.

```

RS232 Menu      5 of 6
Output Term. =  CR/LF

```

Figure 3-9. RS-232 Output Termination display.

When a controller sends data, the downconverter interprets either CR or LF as a terminator, independent of the setting.

### SELECTING THE ECHO MODE

Press the NEXT ITEM button to display the Echo Mode menu (see Figure 3-10). This menu lets you select Echo mode On or Off. Echo mode is intended primarily as a means of interacting with the downconverter from a "dumb" terminal, or for testing purposes. Press CHANGE to select either On or Off.

RS232 Menu	6 of 6
Echo Mode =	Off

**Figure 3-10. RS-232 Echo Mode display.**

When Echo is off, the downconverter does not return the characters it receives to the controller. For most cases, Echo should be off. However, set Echo to On when using a "dumb" terminal to control the downconverter.

When Echo is On, the downconverter echoes each character received back to the controller. This can cause problems for the control program if it is not expecting the characters. Additional time is required to process each returned character, so it is possible to experience buffer overrun if the character rate is too high.

Because Echo mode lets you see each character received by the downconverter, it is sometimes useful for interactive testing. Following are important Echo mode characteristics to remember.

- If Soft flow control is enabled, Ctrl-S or Ctrl-Q are not echoed, but they perform their normal functions
- If either CR or LF is received by the downconverter, it is echoed as the currently selected output terminator
- Any other control character is echoed with no translation

### Installing and Configuring the Device Driver

If you are using special application software or a custom RS-232 driver, follow the detailed instructions for installing and configuring the device driver included with it. However, for PC-type controllers running MS-DOS, the driver is part of the operating system. You can configure a serial communications port with the MODE command by entering a command similar to the following example.

```
MODE COM1:9600,n,8,1
```

This command configures the COM1 interface to run at 9600 baud, no parity, 8 data bits, and 1 stop bit.

### NOTE

*You must use the same set up information for the controller and the downconverter.*

### Communicating with the Downconverter

The RS-232 interface enables remote or automated control of the TDC-10 Tunable Down Converter. An application program (often called a test, measurement, or control program) determines TDC-10 operations by exchanging downconverter-specific messages with the instrument.

The instrument-specific messages are also referred to as device-dependent messages. They are generally understood by, and meaningful to, only the instrument or class of instruments for which they are designed. The organization and description of instrument-specific messages is explained later in this section.

Programmed commands and data are transmitted over the interface to the instrument as soon as they are delivered to the driver. If the command is a query (FETCH:FREQ? for example), the downconverter formats a response immediately and sends it to the computer. The control program is responsible for handling incoming data in a timely fashion.

## Preparing the Software

After completing the setup procedures your equipment is ready for RS-232 operation, but you must still provide the software needed to control the downconverter. When creating new software this is usually a two-step process. The first step is to establish the programming environment. Next, you can create and run the control program. If you are using ready-made control software or application development software, follow the supplier's instructions.

## GPIB AND RS-232 COMMAND REFERENCE

As described earlier, the TDC-10 GPIB interface conforms to IEEE Standards 488.1-1987, 488.2-1987, and Tektronix Standard Codes and Formats 1991. All Tektronix codes and formats, mandatory commands, and several optional commands are supported. For information on the 588.2 and Tektronix codes and formats, see *IEEE 488.2 and Tektronix Codes and Formats Commands* later in this section.

The following types of parameters are used in this section:

<nr1> - integral value.

<nr2> - floating point value

<nr3> - scientific notation value

<nrf> - may be <nr1>, <nr2>, or <nr3>.

<bool> - <nr1>, ON, or OFF. A numeric 0 = OFF; any number other than 0 = ON.

<nondecimal> - hexadecimal, binary, or octal value

<binary> - binary value, i.e. #B0000000001101010

<string> - string type data, i.e. "this is string data"

<char> - character type data

<arb> - arbitrary type data

{<type>}... - one or more occurrences of the parameter 'type' (comma separated)

When applicable, a <nrf> value may include a suffix of HZ, KZ, MZ, or GZ (for Hz, kHz, MHz, or GHz). For example, any parameter representing a visual or aural offset carrier frequency may use these suffixes. An example command would look something like :CTAB:EDIT:AOFF 4.5MZ.

You can determine the shortest version of each command and its parameters from the examples. Uppercase letters specify the shortest form of a command, while lowercase letters are optional. For example, the shortest form of the command :CHANnel:SElect MAXimum would be :CHAN:SEL MAX. The longest form would be :CHANNEL:SELECT MAXIMUM.

All query response examples assume both VERBOSE and HEADER ON.

Table 3-1 shows the allowable value ranges for various argument types.

Table 3-1. Argument types and allowable ranges

Argument Type or Style	Limitations
Channel table name	8 characters from the printable ASCII character set.
Channel number	0 to 999
Channel (video carrier) frequency	$40 \times 10^6$ to $1076 \times 10^6$
Aural offset	$4.5 \times 10^6$ to $6.5 \times 10^6$
Demodulator control bit pattern	Binary or hex digits — only the last 5 bits are used.
Demodulator detector setting	Synchronous or envelope
Intensity	Any value is rounded to 25, 50, 75, or 100 percent
Output IF	$37.0 \times 10^6$ to $45.75 \times 10^6$ ; all values are rounded to nearest installed IF filter (37.0, 38.0, 38.9, or 45.75 MHz).
Input gain	0 to 27 dB, all values are rounded to 0, 17, or 27 dB.
Cal DAC values	0 to 4095
Cal data bank number	0 to 1023
Cal data slot number	0 to 31
Audio and video filter values (Cal only)	0 to 7

## CTABLE Commands

These commands can be used for selecting, listing, copying, defining, and editing channel tables.

### :CTABLE:SELECT

The SELECT subsystem is used to select a channel table by name. The query returns the name of the currently selected channel table.

**Command Format:**        :CTABLE:SElect <string>

**Query Format:**                **Query Response:**  
:CTABLE:SElect?                :CTABLE:SELECT <string>

### Examples

**Command:**                :CTAB:SEL "CATV-STD"

**Query:**                       **Response:**  
:CTAB:SEL?                    :CTABLE:SELECT "B'Cast"

### :CTABLE:CATALOG

The CATALOG subsystem is used to query the names of all tables. Channel table names are returned in multiple <string> response parameters.

**Query Format:**                **Query Response:**  
:CTABLE:CATalog:FIXed?        :CTABLE:CATALOG:FIXED {<string>}...  
:CTABLE:CATalog:USER?         :CTABLE:CATALOG:USER {<string>}...  
:CTABLE:CATalog:ALL?          :CTABLE:CATALOG:ALL {<string>}...

### Example

**Query:**                       **Response:**

:CTAB:CATALOG:FIXED?                   :CTABLE:CATALOG:FIXED "B'Cast","CATV-STD",....

### :CTABLE:AOFFSET

The AOFFSET subsystem is used to query the aural offset carrier frequency for the specified channel table. The name of the channel table is specified by the <string> parameter. The aural offset carrier frequency is returned in the <nr3> response parameter.

#### Query Format:

:CTABLE:AOFFset? <string>

#### Query Response:

:CTABLE:AOFFSET <string>,<nr3>

#### Example

##### Query:

:CTAB:AOFF? "B'Cast"

##### Response:

:CTABLE:AOFFSET "B'Cast",4.500000E+006

### :CTABLE:COPY

The COPY subsystem is used to copy the contents of one channel table to another. The first <string> parameter is the source channel table name, while the second <string> parameter is the destination channel table name. If the destination table exists and is user defined, it is deleted before copy occurs.

**Command Format:**           :CTABLE:COPY <string>,<string>

#### Example

**Command:**                   :CTAB:COPY "CATV-STD","MYTABLE"

### :CTABLE:DELETE

The DELETE subsystem is used to delete the channel table specified by the <string> parameter. Only user defined channel tables may be deleted.

**Command Format:**           :CTABLE:DELete <string>

#### Example

**Command:**                   :CTAB:DEL "MYTABLE"

### :CTABLE:DEFINE

The DEFINE subsystem is used to define and query the contents of a channel table. The <string> parameter specifies the name of the table. The first <nrf> parameter specifies the table's aural offset carrier frequency.

The next three parameters may be repeated for the number of channels in the table. The first of these parameters is the channel number. The second is the frequency of the channel. The last is the skip status of the channel.

### CAUTION

*The DEFINE subsystem is destructive. If the table you define exists, previous data will be destroyed.*

**NOTE**

*A table previously opened via the CTABLE:EDIT:OPEN command is closed when the CTABLE:DEFINE command is issued.*

**Command Format:** :CTABLE:DEFine <string>,<nrf>,{<nrf>,<nrf>,<bool>}...

**Query Format:**

:CTABLE:DEFine? <string>

**Query Response:**

:CTABLE:DEFINE <string>,<nr3>,{<nr1>,<nr3>,<nr1>}...

**Examples**

**Command:** :CTAB:DEF "MYTABLE",5.0e6,1,56e6,OFF,2,100.0e6,OFF,....

**Query:**

:CTAB:DEF? "MYTABLE"

**Response:**

:CTABLE:DEFINE "MYTABLE",5.000000E+006,1,5.600000E+007,0,2,1.000000E+008,0

**:CTABLE:EDIT**

The EDIT subsystem is used to create, edit, change names of, and delete channel tables.

EDIT:OPEN must be issued first. Sending EDIT:CLOSE or opening a new channel closes a previously opened table. The <string> parameter is the name of the table to be edited.

EDIT:RENAME may be used to change the name of an open table to <string>. The name specified must be a new channel table name. This command does not overwrite an existing channel table.

EDIT:AOFFSET sets the aural offset carrier frequency (specified with <nrf>) for the table.

EDIT:APPEND appends channel, channel frequency, and skip status triplets (specified by the <nrf>, <nrf>, and <bool> parameters) to the end of the table.

EDIT:BEFORE is identical to EDIT:APPEND except the leading <nrf> parameter specifies which channel to place the channel, channel frequency, and skip status triplets in front of.

EDIT:DELETE is used to delete a channel (specified with <nrf>) from the table.

EDIT:CLOSE is used to close a table after editing is complete.

The EDIT subsystem modifies only the specified part of the channel table. For example, EDIT:AOFFSET changes only the table aural offset carrier frequency. It does not change channel numbers, frequencies, status, or table names.

**Command Format:** :CTABLE:EDIT:OPEN <string>  
 :CTABLE:EDIT:REName <string>  
 :CTABLE:EDIT:AOFFset <nrf>  
 :CTABLE:EDIT:APPend {<nrf>,<nrf>,<bool>}...  
 :CTABLE:EDIT:BEFore <nrf> {<nrf>,<nrf>,<bool>}...  
 :CTABLE:EDIT:DELeTe <nr1>  
 :CTABLE:EDIT:CLOSe

The following is an example procedure that uses the CTABLE command.

**EXAMPLE: CREATING A CHANNEL TABLE**

Assume that you want to create a channel table named "MyTable", using an audio offset of 4.5 MHz, and including channel 2 at 55.25 MHz, channel 5 at 77.25 MHz, and channel 10 at 193.25 MHz.

Enter the following commands:

```
:CTABLE:EDIT:OPEN "MyTable" ;Prepares the table for editing
:CTABLE:EDIT:AOFFSET 4.5e6 ;Defines the audio offset
:CTABLE:EDIT:APPEND 2,55.25e6,OFF ;Add channel 2
:CTABLE:EDIT:APPEND 5,77.25e6,OFF ;Add channel 5
:CTABLE:EDIT:APPEND 10,193.25e6,OFF ;Add channel 10
:CTABLE:EDIT:CLOSE ;Close the table
```

Notice the third APPEND command parameter. This is the channel's skip status. If the channel is to be defined in the table, but not included in the up/down sequencing, this parameter should be set to ON.

Now, assume that you want to replace channel 5 with channel 3 at 61.25 MHz. You may do this by inserting channel 3 between channels 2 and 5, then deleting channel 5.

```
:CTABLE:EDIT:OPEN "MyTable" ;Prepares the table for editing
:CTABLE:EDIT:BEFORE 5,3,61.25e6,OFF ;Insert the channel
:CTABLE:EDIT:DELETE 5 ;Delete channel 5
:CTABLE:EDIT:CLOSE ;Close the table
```

The new channel table may now be used by selecting it from the channel table menu or by sending the command:

```
:CTABLE:SELECT "MyTable"
```

### HIGH-LEVEL QUERIES

<b>Query Format:</b>	<b>Query Response:</b>
:CTable?	:CTABLE:SELECT <string>

#### Example

<b>Query:</b>	<b>Response:</b>
:CTAB?	:CTABLE:SELECT "B'Cast"

### CHANNEL Commands

The CHANNEL group of commands selects the channel number and controls channel skip status.

#### :CHANNEL:SKIP

The SKIP subsystem is used to control the channel skip feature. SKIP:ENABLE is used to turn the All Channels function on and off. The query returns the boolean status of All Channels mode. SKIP:SELECT is used to set the skip status for the current channel. The query returns the skip status for the current channel.

<b>Command Format:</b>	:CHANnel:SKIP:ENABle <bool>
	:CHANnel:SKIP:SELEct <bool>

<b>Query Format:</b>	<b>Query Response:</b>
:CHANnel:SKIP:ENABle?	:CHANNEL:SKIP:ENABLE <nr1>
:CHANnel:SKIP:SELEct?	:CHANNEL:SKIP:SELECT <nr1>

#### Examples

<b>Command:</b>	:CHAN:SKIP:ENAB ON
<b>Query:</b>	<b>Response:</b>
:CHAN:SKIP:ENAB?	:CHANNEL:SKIP:ENABLE 1



**:CHANNEL:SELECT**

The SELECT subsystem is used to modify the current channel selection. The MAXIMUM parameter sets the channel to the last entry in the current channel table. The MINIMUM parameter sets the channel to the first entry in the current channel table. The UP parameter selects the next channel. The DOWN parameter selects the previous channel. A specific channel number can be selected with the <nrf> parameter.

The query returns the currently selected channel.

**Command Format:**               :CHANnel:SElect MAXimum  
                                   :CHANnel:SElect MINimum  
                                   :CHANnel:SElect UP  
                                   :CHANnel:SElect DOWN  
                                   :CHANnel:SElect <nrf>

**Query Format:**                       **Query Response:**  
 :CHANnel:SElect?                    :CHANNEL:SELECT <nr1>

**Examples**

**Commands:**                       :CHAN:SEL MAX  
                                       :CHAN:SEL MIN  
                                       :CHAN:SEL UP  
                                       :CHAN:SEL DOWN  
                                       :CHAN:SEL 5

**Query:**                               **Response:**  
 :CHAN:SEL?                            :CHANNEL:SELECT 5

**HIGH-LEVEL QUERIES**

**Query Format:**                       **Query Response:**  
 :CHANnel:SKIP?                       :CHANNEL:SKIP:ENABLE <nr1>;  
   SELECT <nr1>  
 :CHANnel?                              :CHANNEL:SELECT <nr1>;  
   SKIP:ENABLE <nr1>;  
   SELECT <nr1>

**Examples**

**Query:**                               **Response:**  
 :CHAN:SKIP?                            :CHANNEL:SKIP:ENABLE 1;SELECT 0  
 :CHAN?                                  :CHANNEL:SELECT 5;SKIP:ENABLE 1;SELECT 0

**FINETUNE Command**

The FINETUNE command is used to control TDC-10 fine tuning. FINETUNE:STATE is used to enable or disable the fine-tune offset capability. FINETUNE:OFFSet is used to set the offset frequency to be applied.

**Command Format:**                   :FINEtune:STATe <bool>  
                                       :FINEtune:OFFSet <nrf>

**Query Format:**                       **Query Response:**  
 :FINEtune:STATe?                      :FINETUNE:STATE <nr1>  
 :FINEtune:OFFSet?                     :FINETUNE:OFFSet <nr3>

:FINEtune? :FINETUNE:STATE <nr1>;  
:FINE:OFFS <nr3>

**Examples**

**Commands:** :FINE:STAT ON  
:FINE:OFFS 3e6

<b>Query Format:</b>	<b>Query Response:</b>
:FINE:STAT?	:FINETUNE:STATE 1
:FINE:OFFS?	:FINETUNE:OFFSET 3.000000E+006
:FINE?	:FINETUNE:STATE 1;OFFSET 3.000000E+006

**TLOCK Command**

The TLOCK command is used to lock out settings that could change TDC-10 tuning.

**Command Format:** :TLOCK <bool>

<b>Query Format:</b>	<b>Query Response:</b>
:TLOCK?	:TLOCK <nr1>

**Examples**

**Commands:** :TLOCK OFF

<b>Query Format:</b>	<b>Query Response:</b>
:TLOCK?	:TLOCK 0

**FETCH:FREQUENCY? Query**

The FETCH:FREQUENCY subsystem is used to return the most recently counted aural offset or visual carrier frequency. If a problem is encountered during count acquisition or if no signal is detected at the downconverter's input, all FETCH queries return 0.0.

**:FETCH:FREQUENCY:AURAL**

The AURAL subsystem is used to return the most recent aural offset carrier frequency.

<b>Query Format:</b>	<b>Query Response:</b>
:FETCh:FREQuency:AURal?	:FETCH:FREQUENCY:AURAL <nr3>

**Example**

<b>Query Format:</b>	<b>Query Response:</b>
:FETC:FREQ:AUR?	:FETCH:FREQUENCY:AURAL 4.491594E+006

**:FETCH:FREQUENCY:VISUAL**

The VISUAL subsystem is used to return the most recent visual carrier frequency.

<b>Query Format:</b>	<b>Query Response:</b>
:FETCh:FREQuency:VISual?	:FETCH:FREQUENCY:VISUAL <nr3>

**Example**

<b>Query Format:</b>	<b>Query Response:</b>
:FETC:FREQ:VIS?	:FETCH:FREQUENCY:VISUAL 7.724992E+007

**HIGH-LEVEL QUERIES****Query Format:**

:FETCh:FREQuency?

**Query Response:**:FETCH:FREQUENCY:AURAL <nr3>;  
VISUAL <nr3>**Example****Query Format:**

:FETC:FREQ?

**Query Response:**:FETCH:FREQUENCY:AURAL 4.489203E+006;VISUAL  
7.724992E+007**MEASURE:FREQUENCY? Query**

The MEASURE:FREQUENCY subsystem is used measure and return a new counted aural offset or visual carrier frequency. If a problem is encountered during count acquisition or if no signal is detected at the downconverter's input, all MEASURE queries return 0.0. To determine which event has occurred, use \*ESR? and ALLEV? to check for errors.

**:MEASURE:FREQUENCY:AURAL**

The AURAL subsystem is used to initiate a new aural offset carrier frequency measurement. The measurement value is returned.

**Query Format:**

:MEASure:FREQuency:AURal?

**Query Response:**

:MEASURE:FREQUENCY:AURAL &lt;nr3&gt;

**Example****Query Format:**

:MEAS:FREQ:AUR?

**Query Response:**

:MEASURE:FREQUENCY:AURAL 4.489577E+006

**:MEASURE:FREQUENCY:VISUAL**

The VISUAL subsystem is used to start a new visual carrier frequency measurement. The measurement value is returned.

**Query Format:**

:MEASure:FREQuency:VISual?

**Query Response:**

:MEASURE:FREQUENCY:VISUAL &lt;nr3&gt;

**Example****Query Format:**

:MEAS:FREQ:VIS?

**Query Response:**

:MEASURE:FREQUENCY:VISUAL 7.724992E+007

**HIGH-LEVEL QUERIES****Query Format:**

:MEASure:FREQuency?

**Query Response:**:MEASURE:FREQUENCY:AURAL <nr3>;  
VISUAL <nr3>**Example****Query Format:**

:MEAS:FREQ?

**Query Response:**:MEASURE:FREQUENCY:AURAL 4.487428E+006;VISUAL  
7.724993E+007

## DEMODO Commands

The DEMODO group of commands is used to control an external 1450 Television Demodulator through its remote interface.

### :DEMODO:CONTROL

The CONTROL subsystem is used to access 1450 Television Demodulator custom mods. Five control lines on the remote connector can be set. The parameter may be in binary, hex, or octal format. The query response returns the parameter in binary format.

**Command Format:** :DEMOd:CONTRol <nondecimal>

**Query Format:** :DEMOd:CONTRol?  
**Query Response:** :DEMODO:CONTROL <binary>

#### Examples

**Commands:** :DEM:CONT #B01101  
 :DEM:CONT #H1E

**Query Format:** :DEM:CONT?  
**Query Response:** :DEMODO:CONTROL #B000000000011110

### :DEMODO:DETECTOR

The DETECTOR subsystem is used to set the 1450 Television Demodulator remote control line for either synchronous or envelope detection. The parameter SYNCHRONOUS sets the 1450 to synchronous detection, while the parameter ENVELOPE sets it to envelope detection. The query returns either SYNCHRONOUS or ENVELOPE, depending on current mode.

**Command Format:** :DEMOd:DETEctor SYNChronous  
 :DEMOd:DETEctor ENVelope

**Query Format:** :DEMOd:DETEctor?  
**Query Response:** :DEMODO:DETECTOR <char>

#### Examples

**Commands:** :DEM:DET SYNC  
 :DEM:DET ENV

**Query Format:** :DEM:DET?  
 :DEM:DET?  
**Query Response:** :DEMODO:DETECTOR ENVELOPE  
 :DEMODO:DETECTOR SYNCHRONOUS

## HIGH-LEVEL QUERIES

**Query Format:** :DEMOd?  
**Query Response:** :DEMODO:CONTROL <binary>;  
 :DETECTOR <char>

#### Example

**Query Format:** :DEM?  
**Query Response:** :DEMODO:CONTROL #B0;DETECTOR SYNCHRONOUS

## INTENSITY Command

The INTENSITY command is used to set readout display intensity. The <nrf> parameter is a numeric value between 25 and 100 representing intensity percent, where 25 is the dimmest display and 100 the brightest. There are only four real values: 25, 50, 75, and 100 percent. Any other number is rounded to the nearest of these four values. The readout display may not be completely switched off (minimum of 25%).

**Command Format:** :INTENsity <nrf>  
**Query Format:** :INTENsity?  
**Query Response:** :INTENSITY <nr1>

### Examples

**Commands:** :INTEN 50  
**Query Format:** :INTEN?  
**Query Response:** :INTENSITY 50

## REFERENCE? Query

The REFERENCE? query is used to determine which reference the TDC-10 is using. Query response can be EXTERNAL or INTERNAL, depending on whether the external or internal reference is in use. If the query response is PENDING, the instrument is attempting to lock all internal oscillators to an external reference signal.

**Query Format:** :REFerence?  
**Query Response:** :REFERENCE <char>

### Examples

**Query Format:** :REF?  
**Query Response:** :REFERENCE INTERNAL  
 :REFERENCE PENDING  
 :REFERENCE EXTERNAL

## IFREQUENCY Command

The IFREQUENCY command is used to set and query the intermediate frequency. The <nrf> parameter is the desired frequency.

**Command Format:** :IFRequency <nrf>  
**Query Format:** :IFRequency?  
**Query Response:** :IFREQUENCY <nr3>

### Examples

**Commands:** :IFR 37e6  
**Query Format:** :IFR?  
**Query Response:** :IFREQUENCY 4.575000E+007

## COUNT:DELTA Command

The COUNT:DELTA command is used to enable and disable Delta Count mode. The query returns the boolean status of the Delta Count mode.

**Command Format:** :COUNT:DELTA <bool>  
**Query Format:** :COUNT:DELTA?  
**Query Response:** :COUNT:DELTA <nr1>

#### Examples

**Commands:** :COUN:DELT ON  
**Query Format:** :COUN:DELT?  
**Query Response:** :COUNT:DELTA 1

## INPUT Commands

The INPUT command is used to specify input power range.

### :INPUT:GAIN COMMAND

The INPUT:GAIN command specifies the input preamplifier gain. You may specify one of three input gain levels, so intermediate values are rounded to the nearest allowable value.

**Command Format:** :INPut:GAIN <nr>  
**Query Format:** :INPut:GAIN?  
**Query Response:** :INPUT:GAIN <nr2>

#### Examples

**Commands:** :INP:GAIN 17  
**Query Format:** :INP:GAIN?  
**Query Response:** :INPUT:GAIN 17

## IEEE 488.2 AND TEKTRONIX CODES AND FORMATS COMMANDS

This section provides a brief description of the IEEE 488.2 and Tektronix Codes and Formats mandatory and optional commands implemented on the TDC-10. For a complete description of these commands, refer to the following source documents:

- IEEE Standard Codes, Formats, Protocols, and Common Commands (ANSI/IEEE Std 488.2-1987)
- Tektronix Std Codes and Formats for use with IEEE Std 488.2 - 1987

### \*CLS Command

The \*CLS command is used to clear the event queue, the Standard Event Status Register (SESR), and the status byte register. If the \*CLS command immediately follows an <EOI>, the output queue and MAV bit (status byte register bit 4) are also cleared. This command also aborts any pending \*OPC or \*OPC? commands. See the Status and Event Handling section for more information.

**Command Format:**                \*CLS

### \*ESR? Query

The \*ESR? query is used to read the contents of the Standard Event Status Register (SESR). The \*ESR? query also clears this register. See the Status and Event Handling section for more information.

<b>Query Format:</b>	<b>Query Response:</b>
*ESR?	<nr1>

### \*STB? Query

The \*STB? query is used to read the contents of the Status Byte Register (SBR) using the Master Summary Status (MSS) bit. See the Status and Event Handling section for more information.

<b>Query Format:</b>	<b>Query Response:</b>
*STB?	<nr1>

### \*PSC Commands

The \*PSC command is used to set and query the power-on status flag that controls the automatic power-on handling of the Device Event Status Enable Register (DESER), the Service Request Enable Register (SRER), and the Event Status Enable Register (ESER).

When \*PSC is set to 1, DESER is set to 255 and SRER and ESER are set to 0 at power on.

When \*PSC is set to 0, the current values of DESER, SRER, and ESER are saved in non-volatile memory at power off, and restored at power on. See the Status and Event Handling section for more information.

<b>Command Format:</b>	*PSC <nrf>
<b>Query Format:</b>	<b>Query Response:</b>
*PSC?	<nr1>

### \*ESE Commands

The \*ESE commands are used to set and query the bits in the Event Status Enable Register (ESER). This register stops events from being reported to the Status Byte Register (STB). See the Status and Event Handling section for more information.

The <nr1> argument is a value in the range from 0 to 255. The ESER binary bits are set according to this value.

The power-on default for ESER is 0 if \*PSC is 1. If \*PSC is 0, the ESER maintains it's value through the power cycle.

<b>Command Format:</b>	*ESE <nrf>	
<b>Query Format:</b>	*ESE?	<b>Query Response:</b>
		<nr1>

## DESE Commands

The DESE commands are used to set and query the bits in the Device Event Status Enable Register (DESER). The DESER is the mask that determines whether events reported to the Standard Event Status Register (SESR) are entered into the event queue. See the Status and Event Handling section for more information.

The <nr1> argument is a value in the range 0 to 255. The DESER bits are set according to this value.

The power-on default for DESER is all bits set if \*PSC is 1. If \*PSC is 0, DESER maintains it's value through the power cycle.

<b>Command Format:</b>	:DESE <nrf>	
<b>Query Format:</b>	:DESE?	<b>Query Response:</b>
		:DESE <nr1>

## \*SRE Commands

The \*SRE commands are used to set and query bits in the Service Request Enable Register (SRER). See the Status and Event Handling section for more information.

The <nr1> argument is a value in the range from 0 to 255. The binary bits of the SRER are set according to this value.

<b>Command Format:</b>	*SRE <nrf>	
<b>Query Format:</b>	*SRE?	<b>Query Response:</b>
		<nr1>

## \*TST Command

The \*TST command is accepted but does not actually run a test, since there are none that can be run by the user. The query response is 0.

<b>Query Format:</b>	*TST?	<b>Query Response:</b>
		<nr1>

## \*OPC Command

The \*OPC command generates the operation complete message in the Standard Event Status Register (SESR) when all pending operations are complete. The \*OPC command does not block the execution of additional commands. Issuing a \*CLS, \*RST, or a device clear aborts the operation complete sequence.

The \*OPC? query places the ASCII character "1" into the output queue when all pending operations are complete. The \*OPC? response cannot be read until all pending operations complete. The



\*OPC? query blocks other commands from running until the operation has completed. A device clear may be issued to abort the operation complete sequence.

**Command Format:**           \*OPC  
**Query Format:**                **Query Response:**  
\*OPC?                            <nr1>

### \*WAI Command

The \*WAI command is used to prevent the device from executing more commands or queries until all previous operations are complete. A device clear may be issued to abort the operation complete sequence.

**Command Format:**           \*WAI

### ALLEV? Query

The ALLEV? query is used to return all events and their messages, and removes the returned events from the event queue. Messages are separated by commas. Use the \*ESR? query to enable events to be returned. See the Status and Event Handling section for more information.

**Query Format:**                **Query Response:**  
:ALLEV?                         :ALLEV {<nr1>,<string>}...

### EVENT? Query

The EVENT? query is used to return an event code from the event queue. The event code provides information about the results of the last \*ESR? read. EVENT? also removes the returned value from the event queue. See the Status and Event Handling section for more information.

**Query Format:**                **Query Response:**  
:EVENT?                         :EVENT <nr1>

### EVMSG? Query

The EVMSG? query is used to return an event code and explanation from the event queue. The event code and explanation provide information about the results of the last \*ESR? read. \*ESR? also removes the returned value from the event queue. See the Status and Event Handling section for more information.

**Query Format:**                **Query Response:**  
:EVMSG?                         :EVMSG <nr1>,<string>

### EVQTY? Query

The EVQTY? query is used to return the number of event codes that are in the event queue. This is useful when using the ALLEV? query, since it tells exactly how many events will be returned. See the Status and Event Handling section for more information.

**Query Format:**                **Query Response:**  
:EVQTY?                         :EVQTY <nr1>

### IDN? Query

The IDN? query is used to query an arbitrary response that contains identification information for the device. The response may look similar to the following:



## \*RST Command

The \*RST command is used to set the device to a known state that is independent of past-use history.

The \*RST command does not change the following:

1. The state of the GPIB (IEEE 488.1-1987) interface.
2. The selected GPIB address.
3. User defined channel tables.
4. The output queue, Service Request Enable Register, Standard Event Status Enable Register, Device Event Status Enable Register, or the power-on status clear flag setting.

Sending the \*RST command is equivalent to issuing the following commands:

```
:CTABLE:SELECT "B'Cast"
:CHANNEL:SELECT 2
:CHANNEL:SKIP:ENABLE 1
:COUNT:DELTA 0
:FINETUNE:STATE 0;OFFSET 0.0
:INPUT:GAIN 0
:IFREQUENCY 45.75E+6
:INTENSITY 100
:DEMOD:CONTROL #B0;DETECTOR SYNCHRONOUS
```

**Command Format:**            \*RST

## HEADER Command

The HEADER command is used to globally enable or disable headers in query responses. This command does not effect IEEE 488.2-1987 Common Commands (those starting with an asterisk), which do not return headers. The HEADER? query returns the current response header enable state.

**Command Format:**            :HEADER <bool>

**Query Format:**                :HEADER?  
**Query Response:**            :HEADER <nr1>

## VERBOSE Command

The VERBOSE command is used to control the length of query response keywords. Keywords can be both headers and responses. Setting VERBOSE on enables full-length keywords for applicable setting queries. Setting VERBOSE off enables minimum-length keywords for applicable setting queries.

This command does not affect IEEE 488.2-1987 Common Commands (those starting with a asterisk).

**Command Format:**            :VERBOSE <bool>

**Query Format:**                :VERBOSE?  
**Query Response:**            :VERBOSE <nr1>

## LOCK Commands

The LOCK command is provided as an alternate to the GPIB LLO and GTL bus commands for locking the front panel (when using RS-232C, this is the only method of locking the front panel).

When a command is issued, the TDC-10 is placed in remote mode. In this state, only the LOCAL key is active. The LOCK ALL command disables all front-panel keys, including LOCAL (the front-panel LOCK LED is lit when the TDC-10 is in this state).

When the LOCK NONE command is issued, all front-panel keys are active until the TDC-10 receives another command (whereupon it re-enters remote mode).

The LOCK? query returns ALL when the front panel is fully locked (front-panel LOCK LED is lit). The query returns NONE when the front panel is completely unlocked or when the TDC-10 is in remote mode (the front panel LOCK LED is off).

### NOTE

*For GPIB operations, the LOCK NONE command does not return the front panel to local mode if the LLO GPIB bus command was originally used to lock it.*

<b>Command Format:</b>	:LOCK NONE	
	:LOCK ALL	
<b>Query Format:</b>		<b>Query Response:</b>
:LOCK?		:LOCK <char>

## UNLOCK Commands

The UNLOCK NONE command is equivalent to LOCK ALL and UNLOCK ALL is equivalent to LOCK NONE. See the description of the LOCK command for details.

<b>Command Format:</b>	:UNLOCK NONE	
	:UNLOCK ALL	
<b>Query Format:</b>		<b>Query Response:</b>
:UNLOCK?		:UNLOCK <char>

## STATUS AND EVENT HANDLING

The TDC-10 provides a status and event reporting system for the GPIB and RS-232C interfaces. This system informs the user of certain events that occur in the TDC-10.

The status handling system consists of five 8-bit registers and two queues. This section describes these registers and components, and explains how the event handling system operates.

### Registers

The registers in the event handling system are in two functional groups:

1. The Standard Event Status Register (SESR) and the Status Byte Register (SBR) contain information about the status of the TDC-10. These are the status registers.
2. The Device Event Status Enable Register (DESER), the Event Status Enable Register (ESER), and the Service Request Enable Register (SRER) determine whether selected types of events are reported to the status registers and the event queue. These are the enable registers.

### STATUS REGISTERS

The Standard Event Status Register (SESR) and the Status Byte Register (SBR) record certain types of events that may occur when the TDC-10 operates. These registers are defined by IEEE 488.2-1987.

Each bit in a status register records a particular type of event, such as an execution error or service request. When an event of a given type occurs, the bit representing that event type is set to one (you can disable bits to ignore events and remain at zero — see the Enable Registers section). Reading the status registers tells you what types of events have occurred.

The SESR records eight types of events that can occur in the TDC-10 (see Table 3-2). You may use the \*ESR? query to read this register. Reading the register clears its bits, enabling it to accumulate information about new events.

**Table 3-2. SESR bit functions**

Bit	Function
7 (MSB)	PON (Power On). Shows that the TDC-10 was powered on.
6	URQ (User Request). Not used.
5	CME (Command Error). Shows that an error occurred while the TDC-10 was parsing a command or query.
4	EXE (Execution Error). Shows that an error occurred while the TDC-10 was executing a command or query.
3	DDE (Device Error). Shows that a device error occurred.
2	QYE (Query Error). Shows that either an attempt was made to read the output queue when no data was present or pending, or that data in the output queue was lost.
1	RQC (Request Control). Not used.
0 (LSB)	OPC (Operation Complete). Shows that the operation is complete.

The Status Byte Register (SBR) records whether output is available in the output queue, whether the TDC-10 requests service, and whether the SESR has recorded events (see Table 3-3).

You may use a serial poll or the \*STB? query to read the contents of this register. The bits in the SBR are set and cleared depending on the contents of the SESR, the Event Status Enable Register (ESER), and the output queue. When you use a serial poll to obtain the SBR, bit 6 is the RQS bit. When you use the \*STB? query to obtain the SBR, bit 6 is the MSS bit.

**Table 3-3. SBR bit functions**

Bit	Function
7 (MSB)	Not used.
6	RQS (Request Service), obtained from a serial poll. Shows that the TDC-10 requests service from the GPIB controller, or MSS (Master Status Summary), obtained from a *STB? query. Summarizes the ESB and MAV bits in the SBR.
5	ESB (Event Status Bit). Shows that status is enabled and present in the SESR.
4	MAV (Message Available). Shows that output is available in the output queue.
3 - 0 (LSB)	Not used.

## ENABLE REGISTERS

The Standard Event Status Register (SESR), Event Status Enable Register (ESER), and Service Request Enable Register (SRER) let you select which events are reported to the status registers and the event queue. Each enable register acts as a filter to a status register (the Device Event Status

Enable Register, DESER, also acts as a filter to the event queue) and can prevent information from being recorded in the register or queue.

Each bit in an enable register corresponds to a bit in the status register it controls. If an event is to be reported to its bit in the status register, the corresponding bit in the enable register must be set to one. If the bit in the enable register is set to zero, the event is not recorded.

The bits in the enable registers are set with commands. The enable registers and commands are described below.

The Device Event Status Enable Register (DESER) controls which types of events are reported to the SESR and the event queue. The bits in the DESER correspond to those in the SESR, as described earlier.

You may use the DESE command to enable and disable the bits in the DESER, and the DESE? query to read the DESER.

The Event Status Enable Register (ESER) controls which types of events are summarized by the Event Status Bit (ESB) in the SBR. The bits in the ESER correspond to those in the SESR, as described earlier.

You may use the \*ESE command to set the bits in the ESE, and the \*ESE? query to read it.

The Service Request Enable Register (SRER) controls which bits in the SBR generate a service request and are summarized by the master status summary (MSS) bit. The bits in the SRER correspond to those in the SBR, but bit 7 is not used.

Use the \*SRE command to set the SRER, and the \*SRE? query to read it. The RQS bit remains set to one until either the Status Byte Register is read with a serial poll or the MSS bit changes to zero.

#### THE ENABLE REGISTERS AND THE \*PSC COMMAND

The \*PSC command controls the contents of the enable registers at power on. Sending \*PSC 1 sets the DESER to 255, the ESER to 0, and the SRER to 0 at power on. Sending \*PSC 0 lets the enable registers maintain their values in non-volatile memory through a power cycle.

#### NOTE

*To enable the PON (Power On) event to generate a service request, send \*PSC 0, use the DESE and \*ESE commands to enable the PON in DESER and ESER, and use the \*SRE command to enable bit 5 in the SRER. Subsequent power-on cycles will generate a Service Request.*

### Queues

The TDC-10 contains an output and an event queue. These are described in the next two sections.

#### OUTPUT QUEUE

The output queue stores query responses. This queue empties each time it receives a new command or query, so query responses must be read before the next command or query is sent. Otherwise, responses to earlier queries are lost and an error may result.

## EVENT QUEUE

The event queue stores detailed information for up to 20 events. If more than 20 events stack up in the event queue, the twentieth event is replaced by event 350: "Too many events".

You may read the event queue with any of these queries:

- `EVENT?`, which returns only the event number
- `EVMSG?`, which returns the event number and a text description of the event
- `ALLEV?`, which returns all the event numbers and a description of the event.

Reading an event removes it from the queue.

Before reading an event from the event queue, you must use the `*ESR?` query to read the event summary from the SESR. This makes the events summarized by the `*ESR?` query available to the `EVENT?` and `EVMSG?` queries and empties the SESR.

Reading the SESR erases events summarized earlier by `*ESR?` reads but not read from the event queue. Events that follow an `*ESR?` read are placed in the event queue but are not available until `*ESR?` is used again.

## Messages

The tables in this section list the programming interface messages generated by the TDC-10 in response to command and query errors.

For most messages, a secondary message from the TDC-10 gives more detail about the cause of the error or the meaning of the message. This message is part of the message string, and is separated from the main message by a semicolon.

Each message is the result of an event. Each type of event sets a specific bit in the SESR, and is controlled by the equivalent bit in the DESER. Thus, each message is associated with a specific SESR bit. In the message tables that follow, the associated SESR bit is specified in the table title, with the exceptions noted with the error message text.

Table 3-4 shows the messages when the system has no events or status to report. These have no associated SESR bit.

**Table 3-4. No event messages**

Code	Message
0	No events to report - queue empty
1	No events to report - new events pending <code>*ESR?</code>

Table 3-5 shows the error messages generated by improper syntax. Check that the command is properly formed and follows the rules for the command outlined in this section.

**Table 3-5. Command error messages – CME Bit 5**

Code	Message
100	Command error
102	Syntax error
103	Invalid separator
104	Data type error
108	Parameter not allowed
110	Command header error
111	Header separator error
112	Program mnemonic too long
113	Undefined header

Table 3-6 lists the execution errors detected during execution of a command.

**Table 3-6. Execution error messages – EXE Bit 4**

Code	Message
222	Data out of range
223	Too much data
224	Illegal parameter value

Table 3-7 lists the device errors that can occur during TDC-10 operation. These errors indicate that the TDC-10 needs repair.

**Table 3-7. Device error messages – DDE Bit 3**

Code	Message
300	Device-specific error
310	System error
311	Memory error
313	Calibration memory lost
350	Queue overflow



Table 3-8 lists the system event messages. These messages are generated when certain system conditions occur.

**Table 3-8. System event messages – QYE Bit 2**

Code	Message
401	Power On (PON Bit 7)
402	Operation complete (OPC Bit 0)
404	Power fail
410	Query INTERRUPTED
420	Query UNTERMINATED
430	Query DEADLOCKED
440	Query UNTERMINATED after indefinite response

Table 3-9 lists the execution warning message that does not interrupt command execution flow.

**Table 3-9. Execution warning message – EXE Bit 4**

Code	Message
500	Execution warning

Table 3-10 lists the internal warning message that is less serious than internal errors. Internal warnings do not interrupt the flow of command execution.

**Table 3-10. Internal warning message – DDE Bit 3**

Code	Message
600	Internal Warning

Table 3-11 lists the extended execution errors. These errors are device specific that do not fit in any of the 200-series errors.

**Table 3-11. Extended execution error messages – EXE Bit 4**

Code	Message
2001	Channel table space full
2002	No channel table open for editing

Table 3-12 lists the extended device-specific error. This error is device specific and does not fit other 300-series errors

**Table 3-12. Extended device-specific error messages - DDE Bit 3**

Code	Message
3001	RS-232C Transfer Failure

## **WARNING**

THE FOLLOWING SERVICING INSTRUCTIONS ARE FOR USE BY QUALIFIED PERSONNEL ONLY. TO AVOID PERSONAL INJURY, DO NOT PERFORM ANY SERVICING OTHER THAN THAT CONTAINED IN OPERATING INSTRUCTIONS UNLESS YOU ARE QUALIFIED TO DO SO. REFER TO OPERATORS SAFETY SUMMARY AND SERVICE SAFETY SUMMARY PRIOR TO PERFORMING ANY SERVICE.





# Section 4

## VERIFICATION AND ADJUSTMENT

### INTRODUCTION

The procedures in this section are of two types: verification and adjustment. The verification procedures verify downconverter operation and may be used to determine whether the downconverter needs readjustment.

Adjustment procedures are used after board exchange or repair, when certain adjustments may be needed to compensate system performance. Follow the directions found in the adjustment procedures part of this section when readjustment is needed.

### VERIFICATION PROCEDURES

The verification procedures in this section verify downconverter operation and may help to determine whether the downconverter needs readjustment.

### Equipment Required

Table 4-1 lists the equipment required to perform the verification procedures.

**Table 4-1. Equipment required for performance verification.**

Device	Description	Supplemental Information
Network Analyzer	3 GHz frequency range	HP8753C or equivalent
S-Parameter test set		HP 85047 or equivalent
RF Signal Generator (low phase noise)	Frequency range: 40 - 1200 MHz; power range: -50 dBm to +10 dBm; SSB phase noise: $\leq 136$ dBc/Hz	HP 8644 or equivalent
RF Signal Generator	Freq. range: 40 - 1200 MHz; power range: -50dBm to +10 dBm	HP 8657B
Power Meter (2)	Power levels: -70 dBm to + 10 dBm; Accuracy: $\pm 0.01$ dBm	HP437B or equivalent
Power Sensor Head	Range: -70 to -20 dBm (> 4.2 GHz)	HP8481D or equivalent
Power Sensor Head	Range: -30 to +20 dBm (> 4.2 GHz)	HP8482A or equivalent
Video Measurement Set	Dual standard (PAL and NTSC)	Tektronix VM700A
Video Measurement Set		Tektronix 1780 (NTSC) or Tektronix 1781 (PAL)
Test Modulator	IF: 45.75 MHz	Tektronix 067-0886-03 or equivalent
Test Modulator	IF: 38.9 MHz	Tektronix 067-0886-05 or equivalent
Video Signal Generator (NTSC)	Five-step staircase and Sin(x)/x wave forms required	Tektronix 1910 or equivalent

Table 4-1. Equipment required for performance verification (cont.)

Device	Description	Supplemental Information
Video Signal Generator (PAL)	Five-step staircase and Sin(x)/x wave forms required	Tektronix TSG271 or equivalent
Spectrum Analyzer		Tektronix 497BP or equivalent
Counter/Timer	2 channels; 100 MHz	Tektronix DC5010
Low-Pass Filter	250 MHz (for ICPM measurements)	Tektronix 105-0352-00
Low-Pass Filter	Attenuation: < 1 dB @ 45 MHz; < 3 dB @ 80 MHz; > 40 dB @ 120 MHz to 1200 MHz	MiniCircuits SLP-90 or equivalent
Directional Coupler	10 MHz to 1 GHz and 40 dB directivity	Wiltron 62N50 or equivalent
Power Divider	50 $\Omega$ (with SMA female connectors)	Tektronix 015-0565-00
TDC Interface Adapter		Tektronix 015-0649-00
Interface Adapter Cable		Tektronix 174-2884-00
Coaxial cable (4 ea.)	Precision 50 $\Omega$ BNC (36 in)	Tektronix 012-0482-00
Coaxial cable (3 ea.)	75 $\Omega$ BNC	Tektronix 012-0159-00
Coaxial Cable (1 ea.)	50 $\Omega$ (SMA connectors)	Tektronix 015-1006-00
Adapters		
N-male to BNC female (3 ea.)	50 $\Omega$	Tektronix 015-0045-00
SMA female to SMA female (2 ea.)		Tektronix 015-1012-00
SMA-male to BNC female (2 ea.)	50 $\Omega$	Tektronix 015-1018-00
SMA-male to N-female	50 $\Omega$	Tektronix 015-1009-00
50 $\Omega$ Terminator	50 $\Omega$ BNC	Tektronix 011-0123-00
20 dB Pad (2 ea.)	50 $\Omega$ SMA	Tektronix 015-1003-00
Hewlett Packard Cal kit		HP 85033C
GPIB/RS-232 Controller		IBM-compatible PC with National Instruments GPIB card (or equivalent equipment) and appropriate software.

**NOTE**

*A 30-minute warm-up period is required for all test equipment and instrumentation used to perform the tests described in this section.*

## Abbreviated Testing

Completely verifying instrument performance requires that the tests in this section be repeated for all TDC-10 channel settings. For an abbreviated procedure, Tektronix recommends performing the tests for the channels shown in Table 4-2<sup>1</sup>.

**Table 4-2. Recommended test channels for abbreviated instrument verification**

Channel	Frequency
2	55.25 MHz
8	181.25 MHz
37	307.25 MHz
59	433.25 MHz
80	558.25 MHz
106	685.25 MHz
127	811.25 MHz
148	935.25 MHz
170	1069.25 MHz

## Power Up Checks

This procedure runs power-on diagnostics and checks for microprocessor kernel errors. The procedure also checks front-panel button function.

1. Connect the TDC-10 Tunable Down Converter to the electrical mains and apply power to the instrument.
2. Check that instrument ID, copyright display, and firmware version are successively displayed as the instrument powers up. The last display shows the channel number in the upper-left corner and channel-table name in the lower-left corner.
3. Note error messages, if any.
4. Check that front-panel buttons are functional:
  - a. Press ALL and check that the LED goes on and off.
  - b. Press SKIP and check that channels increment when the ALL LED is not lit.
  - c. Press MENU and check that this button activates the user menu.
  - d. Press NEXT MENU and check that when the menu is activated five menus can be obtained.
  - e. Press DELTA COUNT and check that the display changes and the DELTA COUNT button LED lights.
  - f. Check for sticking or inoperative front panel buttons.

<sup>1</sup>From cable TV channel table CATV-STD.

## Internal Reference Accuracy

This procedure checks the accuracy of the internal 10 MHz reference oscillator.

### SPECIFICATION

Reference oscillator output frequency:  $10.000000 \text{ MHz} \pm 2 \text{ Hz}$  within one year of calibration.

### CABLING

Connect a cable from the TDC-10 Int Ref Out connector to Channel B of the DC5010 Universal Counter/Timer. Connect a 1 MHz reference signal (accurate to 1 part in  $10^8$ ) to Channel A of the DC5010 Universal Counter/Timer. See Figure 4-1 for an illustration of the test setup.

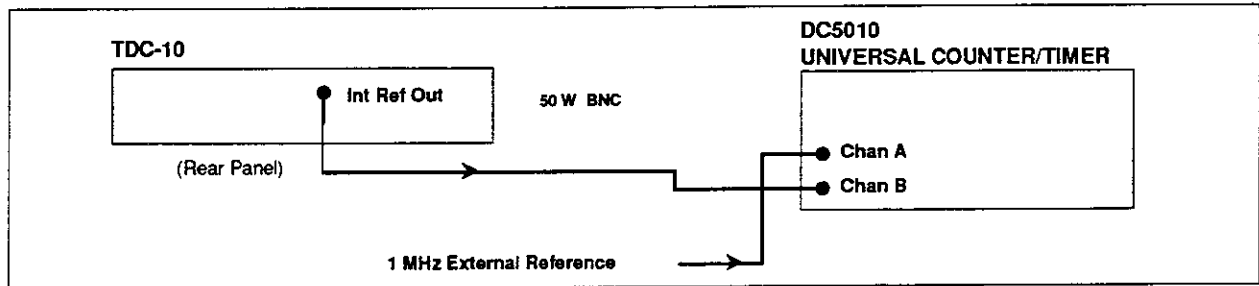

Figure 4-1. Internal reference accuracy test setup.

### SETTINGS

Set the DC5010 Universal Counter/Timer for the following:

Ratio B/A

Channel A and Channel B attenuation X1

Averages  $10^7$

The TDC-10 requires no special settings.

### MEASUREMENT PROCEDURE

Check that the DC5010 Universal Counter/Timer reads  $10.000000 \pm 1$  count.

### NOTE

*Universal counter/timer or counter reference signal accuracy must be greater than 1 part in  $10^8$ .*

## Video Counter Check

This procedure checks that the internal counter and associated detection circuitry are accurate and have the required signal level sensitivity.



**SPECIFICATION**

Accuracy: (Int Ref Accuracy) x ( $F_{in}$ )  $\pm$  2 Hz

With external reference signal: (Ext Ref Accuracy) x ( $F_{in}$ )  $\pm$  2 Hz

Sensitivity: -50 dBm minimum, measured at TDC-10 IF Out.

**CABLING**

Connect the signal generator to the TDC-10 RF Input connector.

**SETTINGS**

1. Signal generator power: -20 dBm.
2. Select a channel via the TDC-10 front panel.
3. Set the signal generator frequency to match the selected channel frequency (channel frequency is displayed on the TDC-10 front panel).
4. Repeat the test with signal generator power set to -50 dBm.

**MEASUREMENT**

Check to see that the front-panel counter display shows the correct frequency count for each channel measured. Check each channel at -20 dBm and at -50 dBm input power.

**NOTE**

*Signal generator frequency accuracy must be 1 part in  $10^8$  or better.*

**Audio Counter Check**

This procedure checks that the audio signal detection circuitry is functional.

**SPECIFICATION**

Accuracy: (Int Ref Accuracy) x ( $F_{in}$ )  $\pm$  2 Hz

With external reference signal: (Ext Ref Accuracy) x ( $F_{in}$ )  $\pm$  2 Hz

Sensitivity: -50 dBm minimum, measured at TDC-10 IF Out.

**CABLING**

Connect two signal generators to a directional coupler and connect the output of the coupler to the RF input of the TDC-10. See Figure 4-2 for an illustration of the test setup.

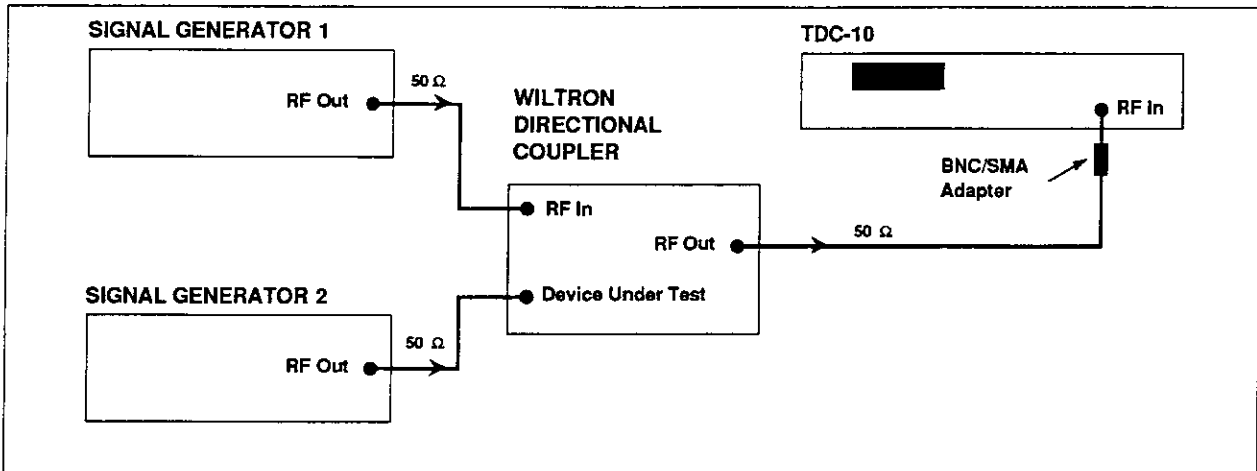

Figure 4-2. Audio counter check test setup.

## SETTINGS

1. Set signal generator 1 and 2 output power to  $-25$  dBm measured at the output of the Wiltron directional coupler.
2. On the TDC-10, verify that the DELTA COUNT and PREAMP LEDs are off.
3. Set the TDC-10 to the selected channel (any channel in the selected channel table).
4. For the selected channel, set signal generator 1 to the video carrier frequency.
5. Set signal generator 2 to the same channel's audio carrier frequency.
6. Check each IF and audio offset combination (see Table 4-3 for these combinations), but only one channel must be tested.

Table 4-3. Channel table audio offsets

Channel Table	Audio Offset (MHz)
CATV-STD	4.5
Eur-BG	5.5
Eur-I	6.0
China-DK	6.5

## NOTE

*Selecting a new active channel may also require changing the TDC-10 IF setting.*

## MEASUREMENT

After about 4 seconds, the front-panel display should indicate the correct video and audio frequencies  $\pm 1$  Hz.

**NOTE**

*The frequency accuracy of the signal generators must be 1 part in  $10^8$ .*

**External Reference Input**

This procedure verifies that the instrument locks to an external reference signal of the correct frequency and amplitude. Phase noise measurement of the IF output signal is required to verify lock.

**SPECIFICATION**

TDC-10 locks to 1, 2, 5, and 10 MHz, 0 to 10 dBm reference signals.

**CABLING**

1. Connect the RF signal generator to the test modulator local oscillator input.
2. Connect a video signal generator to the test modulator video input.
3. Connect the test modulator RF output to the TDC-10 RF input.
4. Connect the TDC-10 IF output to the 1450 IF input.
5. Connect the TDC-10 AGC data input to the TDC-10 interface adapter in the 1450.
6. Connect the 1450 video output (on the rear panel) to any channel input of a 1780 or 1781 video measurement set.
7. Connect the 1450 quadrature output through the specified 250 kHz low-pass filter accessory to the EXT HORIZONTAL input on the rear of the 1780 or 1781.
8. Connect a signal generator to the TDC-10 Ext Ref Input connector.

Figure 4-3 illustrates the setup for the external reference input test procedure.

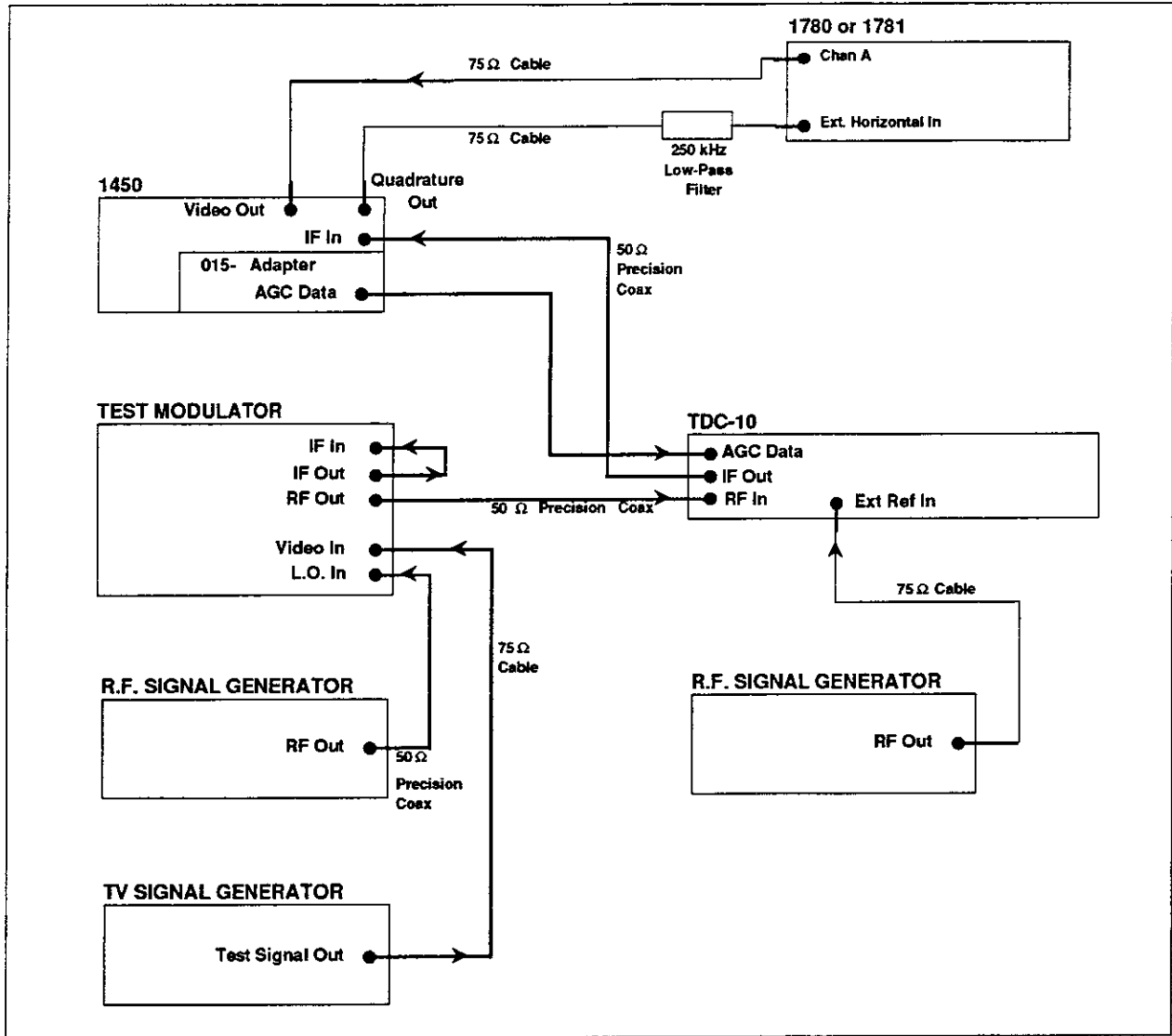

Figure 4-3. External reference input test setup.

**SETTINGS**

1450 Television Demodulator

- Synchronous Detector Time Constant: slow
- Detection Mode: continuous
- Sound Trap: in
- Internal Zero Carrier: off
- Attenuators: none
- Audio Source: N/A
- Auto: Sync Tip
- AGC Speed: slow
- Zero Carrier Pulse: on

**TDC-10**

Select a channel (for example, channel 2)

Set IF to match 1450

Set preamplifier for 0 dB gain

**RF Signal Generator**

Set the frequency according to the TDC-10 IF and channel selected (frequency = IF + channel visual carrier frequency)

Set output power to 0 dBm

**Video Signal Generator**

Set to 5-step staircase wave form (luminance only)

**1780 or 1781 Video Measurement Set**

Press MEASURE and select ICPM measurement on the touch screen

Verify that ALL LINES mode is selected

Use the vertical and horizontal controls to position the zero carrier dot to the crosshairs at the top of the graticule

**MEASUREMENT**

This test is run in two parts. For the first part of the test, perform the cabling steps and instrument settings described above.

1. Use the video measurement set's cursor knob to verify that the displayed ICPM is  $\leq 1.50^\circ$  peak and note the reading.
2. Connect a second signal generator to the TDC-10 external reference and set the generator for 0 dBm at 1 MHz.
3. After the EXT REF LED stops flashing (this takes about one minute), verify that the phase noise is within specifications ( $\leq 1.5^\circ$  peak-to-peak).
4. Select a deviation of 0.1 percent of the 1 MHz reference and observe that the phase noise changes to more than  $2^\circ$ .
5. Repeat for external reference frequencies of 2, 5, and 10 MHz. The deviation required to disturb the phase noise more than  $2^\circ$  is shown below.

External Reference Signal Frequency (MHz)	Deviation Frequency (kHz)
1	1
2	2
5	5
10	10

## Input Return Loss

This procedure checks the reflection coefficient at the instrument's RF input (on any channel).

### SPECIFICATION

Return loss at 40 — 550 MHz: 8.5 dB

Return loss at 550 — 1,076 MHz: 6.0 dB

### CABLING

Using a 50  $\Omega$  SMA cable, connect Port 1 of the network analyzer to the TDC-10 RF Input connector.

### SETTINGS

Network analyzer

Start: 40 MHz

Stop: 1076 MHz

S11 Measurement

Output power: 0 dBm (using 20 dB attenuation on Port 1)

TDC-10

Preamp: 0 dB gain

### PROCEDURE

1. On the network analyzer, perform the S11 one-port calibration with a 50  $\Omega$  SMA cable connected to Port 1.
2. Select a TDC-10 channel.
3. Check that return loss at the selected channel frequency is within specifications.
4. Repeat for all channels or use the channels listed in Table 4-2 for an abbreviated test.
5. Repeat for 17 and 27 dB preamp settings.

## RF Gain and Flatness

This procedure checks the overall gain of the instrument through each signal path (all preamp settings and the two 2nd IF bandpass filters).

### SPECIFICATION

40 – 550 MHz, gain should be 1 dB +0, –4 dB

550 – 860 MHz, gain should be 0 dB +0, –5 dB

860 – 1075 MHz, gain should be 0 dB +0, –8 dB

### NOTE

*Add 17 dB and 27 dB to the nominal values for measurements with preamp set to 17 dB and 27 dB.*

**CABLING**

1. Connect a power meter, power sensor head, and a signal generator to a power divider and connect the power divider through a 6 dB SMA attenuator to the TDC-10 RF Input connector.
2. Connect the TDC-10 Output to a MiniCircuits SLP-90 low-pass filter, and the low-pass filter to a power sensor head and a power meter.

Figure 4-4 illustrates the setup for this test.

**NOTE**

*Two power sensor heads are used in this procedure. The positions of these must be reversed when TDC-10 preamps are selected. Table 4-4 lists the power sensor head that must be used for each TDC-10 preamp setting.*

**Table 4-4. Preamp settings and required power sensor heads.**

TDC-10 Preamp Setting	Input Power Sensor Head	Output Power Sensor Head
0 dB	30 to -20 dBm (HP 8482A)	-20 to -70 dBm (HP 8481D)
17 dB	-20 to -70 dBm (HP 8481D)	30 to -20 dBm (HP 8482A)
27 dB	-20 to -70 dBm (HP 8481D)	30 to -20 dBm (HP 8482A)

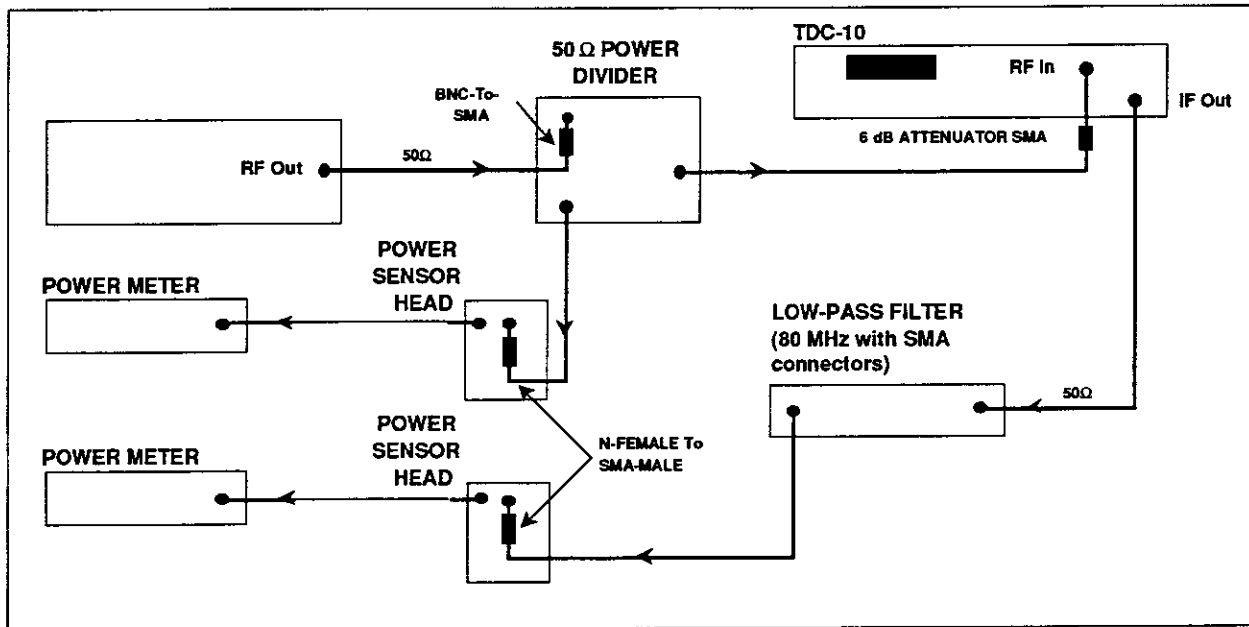

**Figure 4-4. RF gain and flatness test setup.**

**SETTINGS**

TDC-10

0 dB attenuation (no AGC data cable attached)

Preamp to 0 dB gain

IF — make measurements at 45.75 MHz and at your choice of 38.9, 38.0, or 37.0 MHz

Channels — Select the desired channels, checking each with the preamp set to 0 dB. Repeat for 17 and 27 dB.

#### RF Signal Generator

Set to the carrier frequency of the selected channel

Set power level to -10 dBm (with TDC-10 preamp set to 0 dB, or no gain)

Set power level to -27 dBm (with TDC-10 preamp set to 17 dB)

Set power level to -35 dBm (with TDC-10 preamp set to 27 dB)

### NOTE

*These power level settings assume an approximate 6 dB loss in the power divider and that a 6 dB attenuator is used between the power divider and the TDC-10 RF input.*

### PROCEDURE

Measure output and input power on selected channels at each preamp setting. After measuring the input and output power at 0 dBm, be sure to change power sensor heads (refer to Table 4-4) when selecting the 17 or 27 dBm preamps.

### PIN Attenuator AGC Range Check

This procedure checks for AGC range and monotonic response to 1450 gain knob adjustment.

### SPECIFICATION

Check for approximate 0.7 dB steps and monotonicity at selected frequencies. Attenuation over the instrument's frequency range is 0 to a value calculated with the following formula (for maximum attenuation):

$$22 - \frac{f(\text{MHz})}{236.25} \text{ dB}$$

### CABLING

This procedure uses the setup shown in Figure 4-4.

1. Connect a power meter, HP 8482A power sensor head, and a signal generator to a power divider and connect the power divider through a 6 dB SMA attenuator to the TDC-10 RF Input connector.
2. Connect the TDC-10 Output to a MiniCircuits SLP-90 low-pass filter, and the low-pass filter to an HP 8481D power sensor head.
3. Using the 9-pin D-style cable supplied with the TDC-10, connect AGC Data In on the TDC-10 to the 1450 via the interface adapter's AGC Data Out connector.

### SETTINGS

TDC-10

0 dB attenuation



Preamp to 0 dB gain

IF — Make measurements at 45.75 MHz and at your choice of 38.9, 38.0, or 37.0 MHz

Channels — Select the desired channels, checking each with the preamp set to 0 dB. Repeat for 17 dB, and 27 dB.

#### RF Signal Generator

Set to the carrier frequency of the selected channel

Set power level to  $-10$  dBm (with TDC-10 preamp set to 0 dB, or no gain)

### NOTE

*This power level setting assumes an approximate 6 dB loss in the power divider and that a 6 dB attenuator is used between the power divider and the TDC-10 RF input.*

#### 1450 Television Demodulator

Synchronous Detector Time Constant: slow

Detection Mode: continuous

Sound Trap: out

Internal Zero Carrier: off

Attenuators: none

Audio Source: N/A

Auto: Manual

AGC Speed: slow

### PROCEDURE

1. Measure power in versus power out on selected channels.
2. Rotate the 1450's manual gain knob fully counterclockwise (minimum attenuation) and note power input versus. power output at this minimum attenuation level.
3. Gradually rotate the manual gain knob clockwise while checking for a steady decrease in TDC-10 IF output power.
4. With the 1450's manual gain knob rotated fully clockwise, the power output should be 21.7 dB (calculated from the formula above) lower than it was at minimum attenuation.
5. Repeat for all channels or use the channels listed in Table 4-2 for an abbreviated test.

### Residual Signals

This procedure checks for signals independent of the input signal in the TDC-10 IF output passband.

### SPECIFICATION

Non-IF signals:  $\leq -101$  dBm in the 31.5 to 47 MHz band

$\leq -85$  dBm for  $F_{in} = 85$  to 110 MHz

**CABLING**

1. Connect a spectrum analyzer to the TDC-10 IF output.
2. Connect a 50  $\Omega$  terminator to the TDC-10 RF input.

Figure 4-5 shows the setup for this procedure.

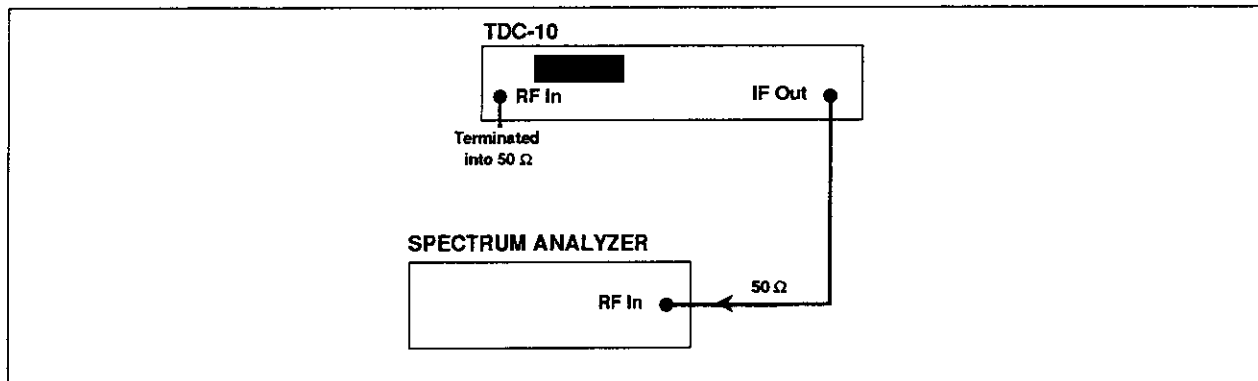

Figure 4-5. Residual signals procedure setup.

**SETTINGS****TDC-10**

IF at 45.75 MHz, and your choice of 37.0, 38.0, or 38.9 MHz

Preamp at 0 dB gain

**Spectrum Analyzer**

Center frequency: 37 MHz

Span: 1 MHz/Div

Reference: -40 dB

Attenuator: 0 dB

RBW: 10 kHz

**PROCEDURE**

1. Set the TDC-10 IF to 45.75 MHz.
2. Set the TDC-10 to the desired channel.
3. Measure the level of non-IF signals in the 31.5 – 47 MHz band with the spectrum analyzer.
4. Repeat the test with the TDC-10 IF set to 37.0, 38.0, or 38.9 MHz.
5. Repeat for all channels or use the channels listed in Table 4-2 for an abbreviated test.

**Third-Order Intercept**

This procedure measures third-order intermodulation distortion using two input signals separated by 2 MHz and 15 MHz.

**SPECIFICATION**

For 2 MHz spacing:

- > 10 dBm with 0 dB preamp gain
- > -7 dBm with 17 dB preamp gain
- > -17 dBm with 27 dB preamp gain

For 15 MHz spacing:

- > 17 dBm with 0 dB preamp gain
- > 0 dBm with 17 dB preamp gain
- > -10 dBm with 27 dB preamp gain

## CABLING

1. Using a directional coupler, connect two RF signal generators to the TDC-10.
2. Connect the output of the TDC-10 to a spectrum analyzer.

Figure 4-6 shows the setup for this procedure.

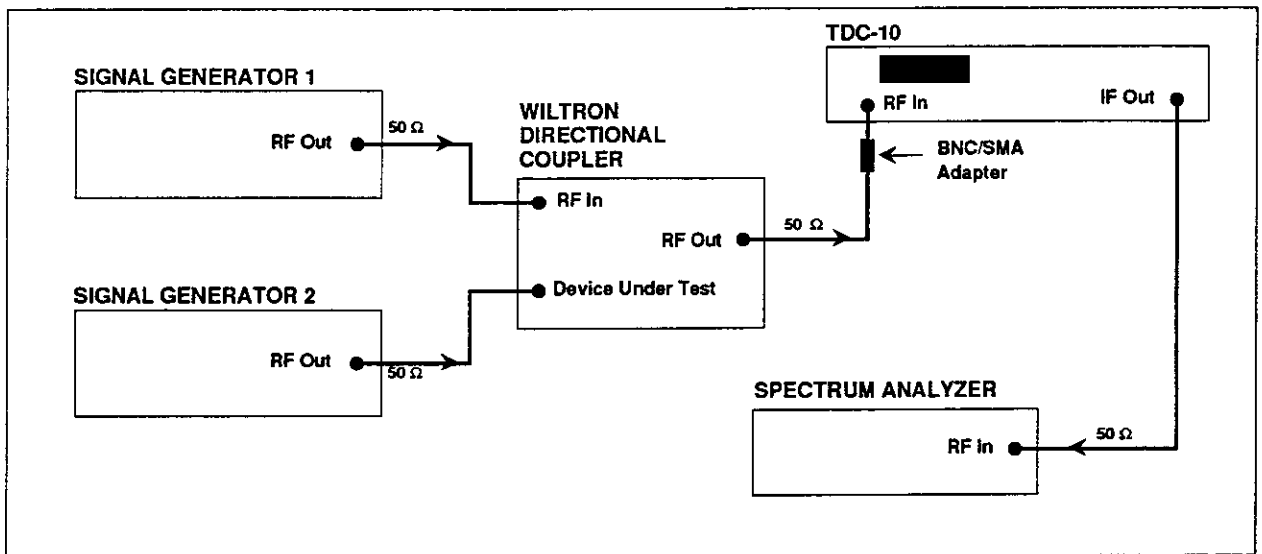

Figure 4-6. Third-order intercept procedure setup.

## SETTINGS

1. Set the TDC-10 to the desired channel.
2. Set RF signal generator 1 power to -16 dBm and the frequency to the video carrier of the selected channel measured at the output of the Wiltron directional coupler.
3. Set RF signal generator 2 power to -16 dBm and the frequency to the video carrier of the selected channel, plus 2 MHz measured at the output of the Wiltron directional coupler.
4. Repeat the test at 15 MHz separation.

## NOTE

*Reduce input signal level to -25 dBm and -35 dBm when testing intermodulation distortion with preamp gain set to ~17 dB and ~27 dB, respectively.*

**NOTE**

*Check the coupler output with a spectrum analyzer and adjust the signal generator power levels to match the power of the two input signals within  $\pm 1$  dB.*

**Spectrum analyzer**

Center frequency: IF setting

Span: 2 MHz/Div

Reference: -10 dB

Attenuator: 30 dB

RBW: 100 kHz

Video Filter: Wide

Min Noise mode

**TDC-10**

Minimum attenuation (AGC data cable not attached).

Perform the checks at each preamp setting (0, 17, and 27 dB) and with each 2nd IF bandpass filter selected (IF set to 45.75 MHz and your choice of 37 - 38.9 MHz selections).

**PROCEDURE**

1. With the spectrum analyzer, measure the amplitude of the intermodulation products that appear 2 MHz above and below the test signals on the IF Out connector of the TDC-10.
2. Verify that the intermodulation products appearing 2 MHz above and below the test signals are greater than 52 dBc for an output signal level of -13 dBm.
3. Repeat for all channels or use the channels listed in Table 4-2 for abbreviated testing.
4. Repeat this test at all preamplifier gain settings.
5. Repeat with a 37 - 38.9 MHz IF selected.

For the 15 MHz spacing test, the TDC-10 must be tuned to channels where third-order intermodulation products are located. For example, with RF generator 1 tuned to 301.25 MHz (channel 37) and RF generator 2 tuned to 316.25 MHz, third-order intermodulation products ( $2f_1 - f_2$  and  $2f_2 - f_1$ ) are at 286.25 MHz (channel 34) and 341.25 MHz (channel 43).

1. With the spectrum analyzer, measure the amplitude of the intermodulation products that appear 15 MHz above and below the test signals on the IF Out connector of the TDC-10.
2. Verify that the intermodulation products appearing 15 MHz above and below the test signals are greater than 66 dBc for an output signal level of -13 dBm.
3. Repeat for all channels or use the channels listed in Table 4-2 for abbreviated testing.
4. Repeat this test at all preamplifier gain settings.
5. Repeat with a 37 - 38.9 MHz IF selected.

Note that you may calculate the third-order intercept point using this formula:

$$IIP_3 = \frac{\text{Intermodulation Suppression (dBc)}}{2} + \text{Input RF Power (dBm)}$$

## Second-Order Intercept

This procedure checks the second-order intercept by injecting signals on two channels and observing second-order modulation products on a third channel.

### SPECIFICATION

45 dBm with preamp gain set to 0 dB (no gain)

28 dBm with preamp gain set to 17 dB

18 dBm with preamp gain set to 27 dB

### CABLING

1. Using a directional coupler, connect two RF signal generators to the TDC-10.
2. Connect the output of the TDC-10 to a spectrum analyzer.

### SETTINGS

For this procedure, select channels and frequencies from Table 4-2.

1. Set signal generator 1 power to  $-16$  dBm and the frequency to the selected channel's video carrier.
2. Set signal generator 2 power to  $-16$  dBm and the frequency to a second channel video carrier.
3. Check the output of the directional coupler with a spectrum analyzer.
4. Set the spectrum analyzer to view both input signals and adjust signal generator power so that both signals are within 1 dB of each other.
5. Connect the directional coupler to the RF input of the TDC-10.
6. Tune the TDC-10 to each of the two selected input channels (see Table 4-5 for recommended settings) and perform the steps of the procedure for each channel.

### NOTE

*Reduce input signal level to  $-25$  dBm and  $-35$  dBm when testing intermodulation distortion with preamp gain set to  $\sim 17$  dB and  $\sim 27$  dB, respectively.*

### PROCEDURE

1. With a spectrum analyzer, measure the amplitude of the intermodulation products that appear at the sum ( $f_1 + f_2$ ) and difference ( $f_2 - f_1$ ) frequencies on the IF Output of the TDC-10 (see Table 4-5 for the recommended frequencies).
2. Verify that the intermodulation products appearing at the sum and difference frequencies are greater than 61 dBc for an output signal level of  $-13$  dBm.
3. Repeat for all channels or use the channels listed in Table 4-2 for abbreviated testing.
4. Repeat this test at each preamplifier gain setting.
5. Repeat the tests with a 37 - 38.9 MHz IF selected.

Table 4-5. Recommended second-order intercept settings.

RF Generator 1 (MHz)	RF Generator 2 (MHz)	f2 + f1 (MHz) (Sum)	f2 – f1 (MHz) (Difference)
55.25 (2)	66	121.25 (14)	—
181.25 (8)	120	301.25 (37)	61.25 (3)
433.25 (59)	168	601.25 (87)	265.25 (31)
811.25 (127)	258	1069.25 (170)	55.25 (59)
937.25 (148)	216	—	721.25 (112)

Note that you may calculate the second-order intercept point using this formula:

$$IIP_2 = \text{Intermodulation Suppression (dBc)} + \text{Input RF Power (dBm)}$$

### NOTE

*For the remaining system checks in this section, the IF of the 1450 and the Tektronix test modulator must match. For complete instrument performance verification, these checks should be performed using two sets of 1450s and test modulators: one set to 45.75 MHz IF and the other set to an IF of 37.0, 38.0 or 38.9 MHz.*

## Signal-to-Noise Ratio

This procedure checks the signal-to-noise performance of the TDC-10 and 1450 system.

### SPECIFICATION

Noise level (unified weighting, 5 MHz low-pass filtered):  $\leq -60$  dB RMS

### CABLING

1. Connect the output of an RF signal generator to the local oscillator input of the test modulator.
2. Connect the TSG170A test signal generator to the video input of the test modulator.
3. Connect the test modulator RF output to the TDC-10 RF input.
4. Connect the TDC-10 IF Out to the 1450 IF input.
5. Connect the TDC-10 AGC data input to the interface adapter's AGC Data Out (the interface adapter is plugged into the 1450).
6. Connect the 1450 Video Out to a signal input (any channel) of a VM700A (terminate the loop-through terminal of this channel with 75  $\Omega$ ).

Figure 4-7 shows the setup for this procedure.

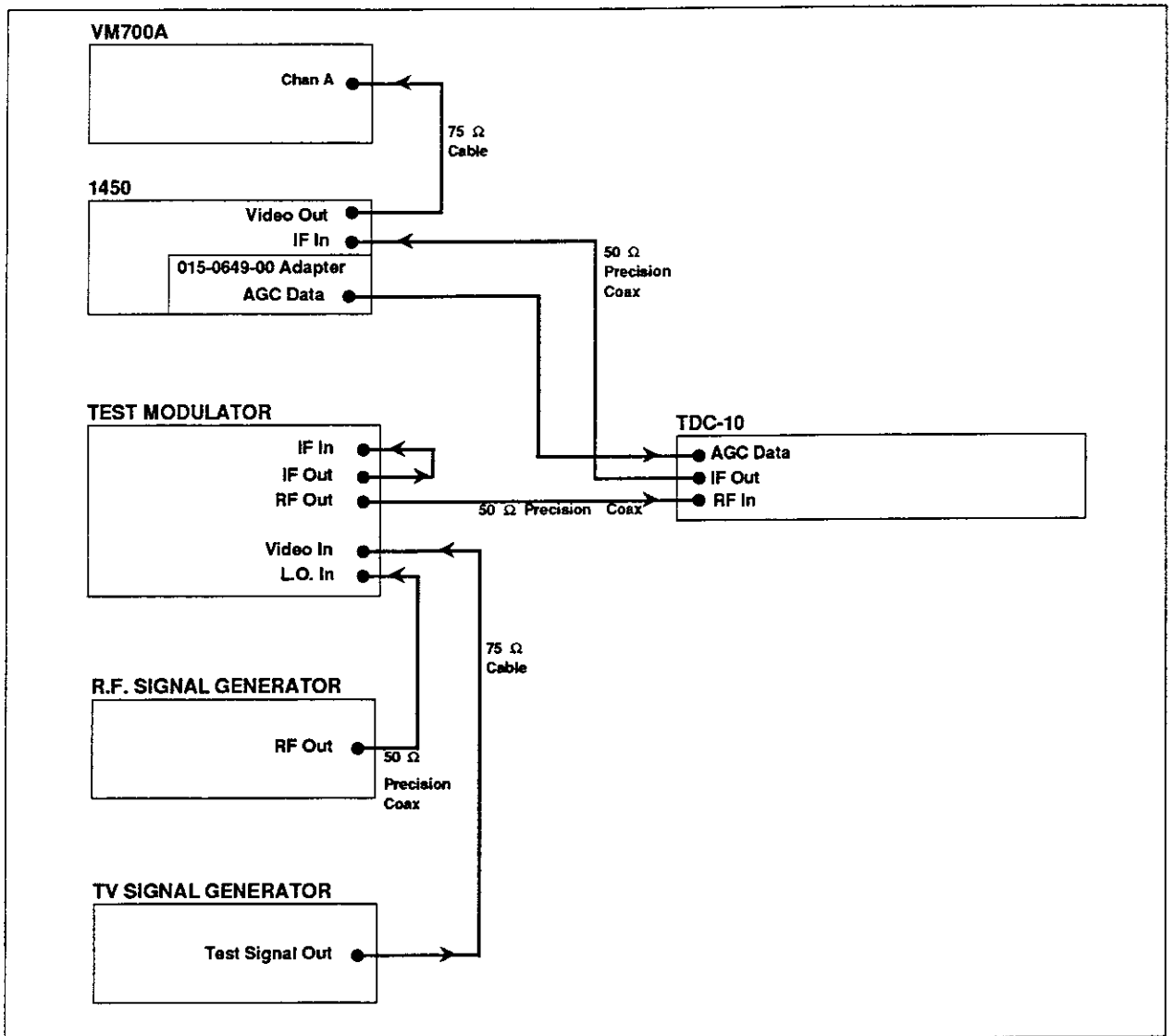

Figure 4-7. Signal-to-noise ratio procedure setup.

## SETTINGS

1. Set the TDC-10 IF to match the IF of the test modulator.
2. Other TDC-10 settings:
  - Preamp: 0 dB
  - Channel: user selectable
3. Test modulator settings:
  - Video Processing: Clamp on; no precorrection
  - Audio Processing: Audio off; Pre-emphasis off
  - Visual IF: Carrier on; Preset enabled
4. Set the TSG170A test signal generator to black burst test wave form.

5. 1450 Television Demodulator settings:
  - Synchronous Detector Time Constant: slow
  - Detection Mode: continuous
  - Sound Trap: out
  - Internal Zero Carrier: off
  - Attenuators: none
  - Audio Source: N/A
  - Auto: sync tip
  - AGC Speed: slow
6. Set the RF signal generator to the frequency determined by the selected IF and channel (frequency = IF + nominal channel carrier frequency).
7. Set the output power of the signal generator to  $-5$  dBm.
8. Set the VM700A to the input channel and perform these steps:
  - a. Press Select Line and rotate the knob to obtain a black burst display line.
  - b. Press the Measure button to enter Measure mode.
  - c. Press the Noise Spectrum soft key.
  - d. Press the front-panel Menu button and the Filter Selections soft key, then select Unified Weighting (the Unified Weighting and 5 MHz Low Pass Filter soft keys should be lighted).
  - e. Press the Average front-panel button to select Average mode.

## PROCEDURE

Check to see that the displayed noise level readout is  $\leq -60$  dB RMS. Check all channels, or those listed in Table 4-2.

## Noise Figure

This procedure checks the input noise figure of the TDC-10 on any channel.

## SPECIFICATION

40 - 550 MHz:	$\leq 25$ dB at $\sim 0$ dB preamp gain
	$\leq 13$ dB at $\sim 17$ dB preamp gain
	$\leq 9$ dB at $\sim 27$ dB preamp gain
550 - 860 MHz:	$\leq 26$ dB at $\sim 0$ dB preamp gain
	$\leq 14$ dB at $\sim 17$ dB preamp gain
	$\leq 10$ dB at $\sim 27$ dB preamp gain
860 - 1076 MHz:	$\leq 30$ dB at $\sim 0$ dB preamp gain
	$\leq 18$ dB at $\sim 17$ dB preamp gain
	$\leq 14$ dB at $\sim 27$ dB preamp gain

## CABLING

1. Connect the output of an RF signal generator to the local oscillator input of the test modulator.
2. Connect the TSG170A test signal generator to the video input of the test modulator.



3. Connect the RF output of the test modulator to the spectrum analyzer and make the measurement.
4. Connect the TDC-10 AGC data input to the interface adapter's AGC Data Out (the interface adapter is connected to the 1450).
5. Connect the 1450 Video Out to a signal input (any channel) of a VM700A (terminate the loop-through terminal of this channel with 75  $\Omega$ ).
6. Connect the test modulator RF output to the TDC-10 RF input (RF level is -25 dBm).

## SETTINGS

Set the VM700A to the input channel and perform these steps:

1. Press Select Line and rotate the knob to obtain a black burst display line.
2. Press the Measure button to enter Measure mode.
3. Press the Noise Spectrum soft key.
4. Press the front-panel Menu button and the Filter Selections soft key, then select Unified Weighting (the Unified Weighting and 5 MHz Low Pass Filter soft keys should be lighted).
5. Press the Average front-panel button to select Average mode.

Set the spectrum analyzer to these settings:

Center Frequency: RF input frequency (channel under test)

Span: 2 MHz/Div

Reference Level: -50 dBm

Attenuator: 10 dB

RBW: 3 MHz

Max Hold: On

## PROCEDURE

1. Measure the modulated RF level with a calibrated spectrum analyzer.
2. Measure signal-to-noise at this setting on the VM700A.
3. Compute the noise figure (NF) according to the formula:

$$NF = 108 - (RF_{in} + \text{Noise Level})$$

Example: RF input level: -40 dBm

VM700A Noise Level: -53 dB RMS

$$NF = 108 - (-40 - 53) = 15 \text{ dB}$$

4. Insert two 20 dB pads in the RF signal path and repeat the measurement for 17 and 27 dB gain settings.
5. Repeat for each gain setting and recommended test channel.

## Phase Jitter

This procedure measures TDC-10 phase jitter on various channels.

**SPECIFICATION**

Phase Jitter:  $\leq 1.50^\circ$  peak

**CABLING**

1. Connect the RF signal generator to the test modulator local oscillator input.
2. Connect a video signal generator to the test modulator video input.
3. Connect the test modulator RF output to the TDC-10 RF input.
4. Connect the TDC-10 IF output to the 1450 IF input.
5. Connect the TDC-10 AGC data input to the TDC-10 interface adapter in the 1450.
6. Connect the 1450 video output (on the rear panel) to any channel input of a 1780 or 1781 video measurement set.
7. Connect the 1450 quadrature output through the specified 250 kHz low-pass filter accessory to the EXT HORIZONTAL input on the rear of the 1780 or 1781.
8. Connect a signal generator to the TDC-10 Ext Ref Input connector.

Figure 4-8 shows the setup for this procedure.

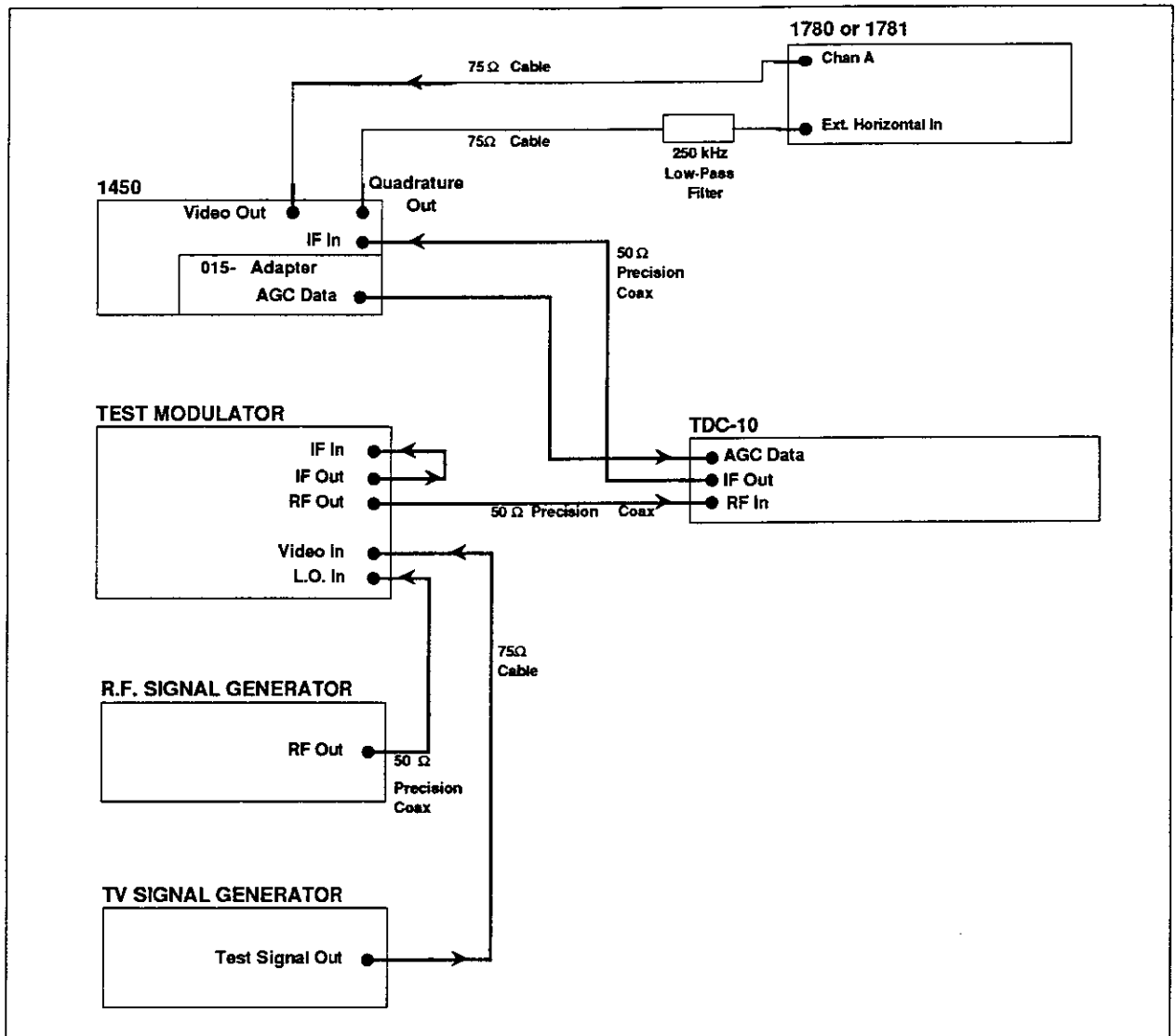

Figure 4-8. Phase jitter setup.

**SETTINGS**

## 1450 Television Demodulator

Synchronous Detector Time Constant: slow

Detection Mode: continuous

Sound Trap: in

Internal Zero Carrier: off

Attenuators: none

Audio Source: N/A

Auto: Sync Tip

AGC Speed: slow

Zero Carrier Pulse: on

**TDC-10**

Set IF to match 1450 and test modulator

Set preamplifier for 0 dB gain

**RF Signal Generator**

Set to frequency based on TDC-10 IF and selected channel (frequency = IF + nominal visual carrier frequency)

Set output power to 0 dBm

**Video Signal Generator**

Set to 5-step staircase wave form (luminance only)

**1780 or 1781 Video Measurement Set**

Press MEASURE and select ICPM measurement on the touch screen

Verify that ALL LINES mode is selected

Use the vertical and horizontal controls to position the zero carrier dot to the crosshairs at the top of the graticule

**PROCEDURE**

Check to see that the displayed ICPM readout is  $\leq 1.50^\circ$  peak. Test all channels or use the channels shown in Table 4-2 for abbreviated testing.

**In-Channel Magnitude Flatness**

This procedure checks TDC-10 frequency response flatness for the passband of each channel.

**SPECIFICATION**

In-Channel Magnitude Flatness:  $\leq \pm 0.4$  dB variation across passband for VBW = 4.2 MHz.

$\leq \pm 0.65$  dB variation across passband for VBW = 5.0 MHz,  
5.5 MHz, 6.0 MHz.

**CABLING**

1. Connect the RF signal generator to the test modulator local oscillator input.
2. Connect a video signal generator to the test modulator video input.
3. Connect the test modulator RF output to the TDC-10 RF input.
4. Connect the TDC-10 IF output to the 1450 IF input.
5. Connect the TDC-10 AGC data input to the TDC-10 interface adapter in the 1450.
6. Connect the 1450 video output (on the rear panel) to any channel input of a VM700A video measurement set.

**SETTINGS****1450 Television Demodulator**

Synchronous Detector Time Constant: slow

Detection Mode: continuous

Sound Trap: out  
Internal Zero Carrier: off  
Attenuators: none  
Audio Source: N/A  
Auto: Sync Tip  
AGC Speed: slow

#### TDC-10

Set IF to match 1450 and test modulator  
Set preamplifier for 0 dB gain, but check also at 17 and 27 dB settings

#### RF Signal Generator

Set to frequency based on TDC-10 IF and selected channel (frequency = IF + nominal visual carrier frequency)  
Set output power to 0 dBm

#### Video Signal Generator

Set to multiburst wave form

#### VM700A Video Measurement Set

Press the Waveform button to view signal  
Press Select Line and rotate the knob to view the multiburst display line  
Press Measure to place the instrument in Measure mode  
Select MultiBurst with the soft key  
Press Menu  
Select dB Reference with the soft key  
Select 0 dB Ref Flag with the soft key  
a. Rotate the KNOB to select the reference packet that most evenly splits the waveform between a positive and negative deviation.  
Press Average to select averaging mode

Normalize the setup with the following procedure:

1. Detach the IF connections from the TDC-10, test modulator, and the 1450.
2. Connect the test modulator IF output to the 1450 IF input.
3. Establish a reference with the VM700A:
  - a. Press Menu, then press the Reference and Store Reference (1) soft keys.
  - b. After the beep, press the Relative to Reference and Use (1) Reference soft keys.
4. Replace the cables on the TDC-10, test modulator, and 1450.

## PROCEDURE

Check to see that the multiburst levels displayed vary  $\leq \pm 0.4$  dB for VBW = 4.2 MHz (minimum to maximum) and  $\leq \pm 0.65$  dB for VBW = 5.0 MHz, 5.5 MHz, 6.0 MHz. Repeat for all channels, or use the channels listed in Table 4-2 for abbreviated testing.

## In-Channel Group Delay Flatness

This procedure checks the TDC-10 group delay response flatness for the passband of each channel. The procedure requires the use of a Sin (x)/x test signal. Because the recovered signal to noise ratio is approximately 60 dB, this method of group delay measurement is erratic when measuring delay flatness of a few nanoseconds. To ensure an accurate measurement, the normalization procedure described below should be performed just before the group delay measurement is made.

## SPECIFICATION

In-Channel Group Delay Flatness:  $\pm 12$  ns group delay as measured with the VM700A test set

## CABLING

1. Connect the RF signal generator to the test modulator local oscillator input.
2. Connect a video signal generator to the test modulator video input.
3. Connect the test modulator RF output to the TDC-10 RF input.
4. Connect the TDC-10 IF output to the 1450 IF input.
5. Connect the TDC-10 AGC data input to the TDC-10 interface adapter in the 1450.
6. Connect the 1450 video output (on the rear panel) to any channel input of a VM700A video measurement set.

Figure 4-7 shows the setup for this procedure.

## SETTINGS

### 1450 Television Demodulator

Synchronous Detector Time Constant: slow

Detection Mode: continuous

Sound Trap: out

Internal Zero Carrier: off

Attenuators: none

Audio Source: N/A

Auto: Sync Tip

AGC Speed: slow

### TDC-10

Set IF to match 1450 and test modulator

Set preamplifier for 0 dB gain, but check also at 17 and 27 dB settings

### RF Signal Generator

Set to frequency based on TDC-10 IF and selected channel (frequency = IF + nominal visual carrier frequency)

Set to frequency based on TDC-10 IF and selected channel (frequency = IF + nominal visual carrier frequency)

Set output power to 0 dBm

#### Video Signal Generator

Set to multiburst wave form

#### VM700A Video Measurement Set

Press **SELECT LINE** and rotate the knob to view the multiburst display line

Press **MEASURE** to place the instrument in Measure mode

Select **MultiBurst** with the soft key

Press **AVERAGE** to select averaging mode

Set to **Sin (x)/x** wave form with the following steps:

- a. Press **Select Line** and rotate knob to obtain a **sin (x)/x** wave form
- b. Press the **MEASURE** button to enter measure mode
- c. With the soft key, select **Sin (x)/x**
- d. Press the **AVERAGE** button to select average mode
- e. Press the **Utility** soft key to display the **Averages** submenu
- f. Press the **# Averages** soft key and rotate the knob to set the number of averages to 100

Normalize the setup with the following procedure:

1. Detach the IF connections from the TDC-10, test modulator, and the 1450.
2. Connect the test modulator IF output to the 1450 IF input.
3. Establish a reference with the VM700A:
  - a. Press **MENU**, then press the **Reference and Store Reference (1)** soft keys.
  - b. After the beep, press the **Relative to Reference and Use (1) Reference** soft keys.
4. Replace the cables on the TDC-10, test modulator, and 1450.

#### PROCEDURE

Check to see that the group delay flatness is within  $\pm 12$  nsec. Repeat for all channels or use the channels listed in Table 4-2 for abbreviated testing.

## GPIB Port

This procedure checks the GPIB port for operation.

### PROCEDURE

1. Enable the GPIB port from the menu by changing its status to On Line (see *Setup and Operation* for more information).
2. Display the Address menu and note the GPIB address setting.
3. Use the TDC-10 GPIB address to communicate with the controller.
4. Connect a GPIB controller to the TDC-10 via a standard GPIB cable.
5. Use the \*IDN? query and check for a response from the TDC-10.
6. Disable the GPIB port from the menu by changing its status to Off Line.

The response should be a message similar to: "TEKTRONIX TDC10, version 08....., etc", depending on firmware version.

For further checks, use a command that changes the channel (or any other command that changes some instrument state) and check for execution.

## RS-232 Port

These checks are identical to the GPIB checks, but using the RS-232 menu. Check to see that baud rates and parity settings (found in the RS-232 menu) match the terminal or console being used to check the instrument.

1. Connect the controller or terminal serial port to the RS-232 port on the rear panel of the TDC-10.
2. Use the Menu key to display the TDC-10 baud rate and parity settings.
3. Set the controller or terminal serial port to the baud rate and parity settings on the TDC-10.
4. Use the \*IDN? query and check for a response from the TDC-10.

The response should be a message similar to: "TEKTRONIX TDC10, version 08....., etc", depending on firmware version.

Repeat these steps for all baud rate and parity settings.



## ADJUSTMENT PROCEDURES

The adjustment procedures in this section are used after board exchange or repair, when certain adjustments may be needed to return the instrument to operation. Follow the directions in this section when readjustment is needed.

### Equipment Required

Table 4-6 lists the equipment required to perform the adjustment procedures in this section.

**Table 4-6. Equipment required for adjustment procedures.**

Device	Description	Supplemental Information
Digital voltmeter		Tektronix DM501A
Voltage source		Tektronix PS503A
Television test signal generator		Tektronix TSG170A
Network analyzer		HP 8753C
Test modulator	Any -00 through -05 is suitable	Tektronix 067-0886-xx
RF signal generator	(0 dBm signal, 40 MHz to 2 GHz)	HP 8657B
Programmable spectrum analyzer		Tektronix 492BP
50 $\Omega$ BNC-to-BNC cable	4 each	Tektronix 012-0482-00
75 $\Omega$ BNC-to-BNC cable	1 each	Tektronix 012-0159-00
BNC male-to-SMA-female adapter	2 each	Tektronix 015-1018-00
SMA female-to-female adapter	1 each	Tektronix 015-1012-00
Programmable counter/timer		Tektronix DC5010
Hewlett Packard Cal kit		HP 85033C

### 10 MHz Reference Oscillator

This procedure describes how to adjust the 10 MHz internal reference oscillator.

#### CABLING

Connect a cable from the TDC-10 Int Ref Out connector to Channel B of the DC5010 Universal Counter/Timer. Connect a 1 MHz reference signal (accurate to 1 part in  $10^8$ ) to Channel A of the DC5010 Universal Counter/Timer. See Figure 4-9 for an illustration of the test setup.

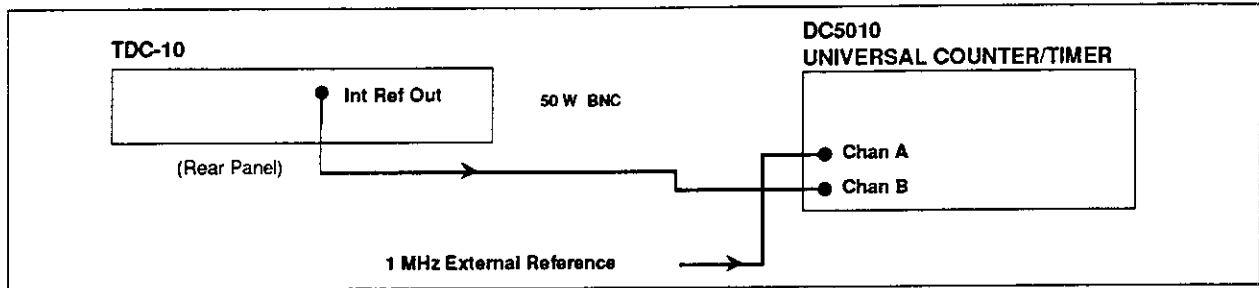

Figure 4-9. Internal reference accuracy test setup.

## SETTINGS

Set the DC5010 Universal Counter/Timer for the following:

Ratio B/A

Channel A and Channel B attenuation X1

Averages  $10^7$

The TDC-10 requires no special settings.

## PROCEDURE

1. Remove the adjustment access hole screw from the oscillator housing.
2. Locate the oscillator frequency adjustment screw inside the access hole.
3. Adjust the oscillator frequency to  $10.0000000 \text{ MHz} \pm 0.2 \text{ MHz}$  (note that it takes about 5 seconds for the counter reading to update).

## 100 MHz Distribution Board

This procedure describes adjusting the 100 MHz filter and the phase lock loop on the 100 MHz Distribution board.

## SETUP

1. With a  $50 \Omega$  cable connected to port 1, calibrate the network analyzer for an S11 measurement at port 1.
2. Move the jumper on J1612 (100 MHz Distribution board) from position 1-2 to position 2-3.
3. Disconnect the cable at J1609 (from the 3rd Converter) and connect a cable to the network analyzer Port 1 in its place.
4. Install a jumper across the two pins of J1614.
5. Set the network analyzer:
  - Center Frequency: 100 MHz
  - Span: 20 MHz
  - Power: 0 dBm
6. Connect a cable from Port 1 of the network analyzer to J1609.

**PROCEDURE****Adjust the 100 MHz filter**

1. Adjust C96 for a relative minimum return loss (somewhere in the  $-10$  to  $-30$  dB range).
2. Move the jumper from J1614 to J1613.
3. Adjust C97 for a relative maximum return loss (somewhere in the  $-7.5$  to  $0$  dB range).
4. Remove the jumper from J1613.
5. Adjust C98 for a relative minimum return loss (somewhere in the  $-10$  to  $-30$  dB range).
6. Return the jumper on J1612 to position 1-2.
7. Remove the network analyzer cable from J1609 and reattach the cable from the 3rd Converter.

**Adjust the 100 MHz Phase Lock****NOTE**

*Use a non-metallic tool for this adjustment.*

1. Connect the digital multimeter's positive test lead to TP1 and the negative test lead to any ground.
2. Adjust C46 (the phase lock voltage adjustment) for .880 V at TP1.
3. Remove test leads.

**Inter-Carrier Processor Board**

This procedure describes adjusting the visual IF filters on the Inter-Carrier Processor board.

**SETUP**

1. Using a  $75\ \Omega$  BNC cable, connect a TV signal generator to the video input of the test modulator.
2. Use a  $50\ \Omega$  BNC cable and a BNC-to-SMA adapter to connect an RF signal generator to the local oscillator input of the test modulator.
3. Use a  $50\ \Omega$  BNC cable and BNC-to-SMA adapter to connect the test modulator RF output to the TDC-10 RF input.
4. Use a  $50\ \Omega$  BNC cable to connect the test modulator IF input to the test modulator IF output.
5. Set the test modulator:
  - Video Processing: Clamp: on
  - Precorrector: off
  - Visual Carrier IF: on
  - Preset: on
  - Aural IF – Crystal: off; Carrier: off; Modulate: off
6. Set the spectrum analyzer:
  - Span: 2 MHz

Ref: 10 dBm

Count: on

Resolution: 100 Hz

7. Set the TDC-10 to channel 2 (carrier frequency 55.25 MHz)
8. Check the test modulator's IF setting (shown on the rear-panel label).
9. Calculate the RF generator frequency setting using this formula:
 
$$\text{RF Generator Output Frequency} = 55.25 + \text{test modulator IF in MHz}$$
10. Set the RF signal generator to the calculated frequency and 0 dBm power output.
11. Connect the input of the spectrum analyzer to J2 (IF carrier out) on Inter-Carrier Processor board.
12. Connect the positive lead of the digital voltmeter to TP2 on the Inter-Carrier Processor board.

Figure 4-10 shows the setup for this procedure.

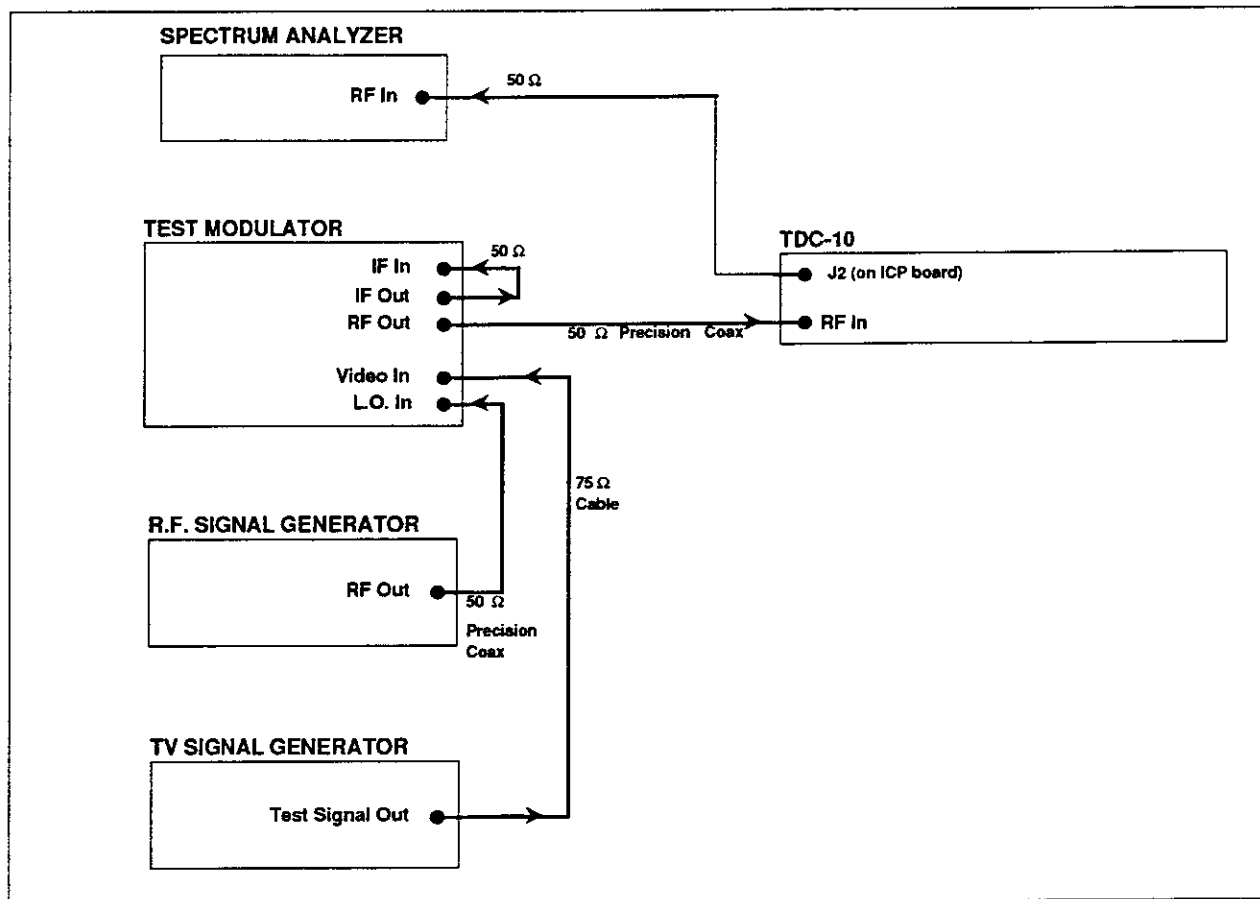

Figure 4-10. Inter-Carrier Processor board adjustment setup.

## PROCEDURE

### Adjust the visual IF filter

1. Enable the TDC-10 Tuning Menu by pressing the MENU button.
2. Press the NEXT ITEM button to locate the IF adjustment menu.

3. Use this menu to set the TDC-10 to the required IF.
4. Use the following steps to adjust L1, R28, R3, and R30 for a stable output frequency on the spectrum analyzer.
  - a. Adjust L1 for the output frequency specified below, then perform a fine adjustment to obtain 3.12 V at TP2.
  - b. Adjust R30 for the frequencies indicated below at 3.12 V (measured at TP2).
  - c. Repeat for R29 and R28.

For this IF	Adjust	For this Output Frequency
45.75 MHz	L1	22.875 MHz
37.00 MHz	R30	18.50 MHz
38.00 MHz	R29	19.00 MHz
38.90 MHz	R28	19.45 MHz

## YIG Driver Board

This procedure describes how to adjust the YIG oscillator driver gain and offset.

### SETUP

1. Enter Calibration Assistance mode (see *Troubleshooting and Maintenance* for information on configuring the TDC-10 for Calibration Assistance mode).
2. Power off the TDC-10, then power it on to invoke Calibration Assistance mode.
3. Select the YIG driver adjust on the TDC-10 display by using the up- or down-arrow keys.

### PROCEDURE

#### Adjust the -10V reference

1. Connect a digital voltmeter between TP2 and ground.
2. Adjust R13 for -10.0 V (at TP2).

#### Adjust the DAC offset and coarse gain

For this procedure, press the backspace key to switch between DAC = 0 and DAC = 16383.

1. Set the DAC to 0 and adjust R36 for minimum error.
2. Set the DAC to 16383 and adjust R37 for minimum error.
3. Repeat these steps until the error is less than 5 MHz.

#### Fine adjust R36 and R37

1. If the TDC-10 display shows the same error sign (both + or both -) for DAC = 0 and DAC = 16383, adjust the offset, R36.
2. If the display shows opposite error signs (one + and one -) for DAC = 0 and DAC = 16383, adjust the gain, R37.
3. Adjust R36 and R37 for less than 2 MHz error at DAC = 0 and DAC = 16383 settings.

**NOTE**

*These adjustments interact and react slowly. Allow 15 seconds between adjustments.*